

ECE4634

Digital Communications

Fall 2007

Instructor: R. Michael Buehrer
Lecture #11: Pulse Shaping



Analog and Digital Communications



Pulse Shaping

- The spectrum of the signal is dependent on the spectrum of the pulse used, the pulse rate as well as the autocorrelation of the data.

$$P_x(f) = \frac{|F(f)|^2}{T_s} \sum_{k=-\infty}^{\infty} R(k) e^{j2\pi f k T_s}$$

- Often we wish to control aspects of the transmission bandwidth.
- We saw last time how we can control spectral characteristics using different line codes
 - controls the autocorrelation and pulse duration
- Now we turn look at controlling spectrum by controlling the shape of the pulse used.
- This is termed pulse shaping and allows us to maximize data rate within a given bandwidth
- What to read – Sections 6.3 and 6.4



Lecture Objectives

- In this lecture we will demonstrate that
 - pulse shaping allows us to control the spectral parameters of the signal
 - there are limits to what can be done with a pulse that is limited to duration T
 - we can reduce bandwidth by allowing the pulse duration to be more than the time between consecutive pulses (T) but in general this leads to ISI
 - a family of pulses termed *Nyquist pulses* or *raised cosine pulses* provide minimum bandwidth with zero ISI

The Spectral Mask

- The Federal Communications Commission (FCC) and many system designers typically specify bandwidth constraints using the *spectral mask*.
- A spectral mask describes the maximum power allowed within a certain bandwidth

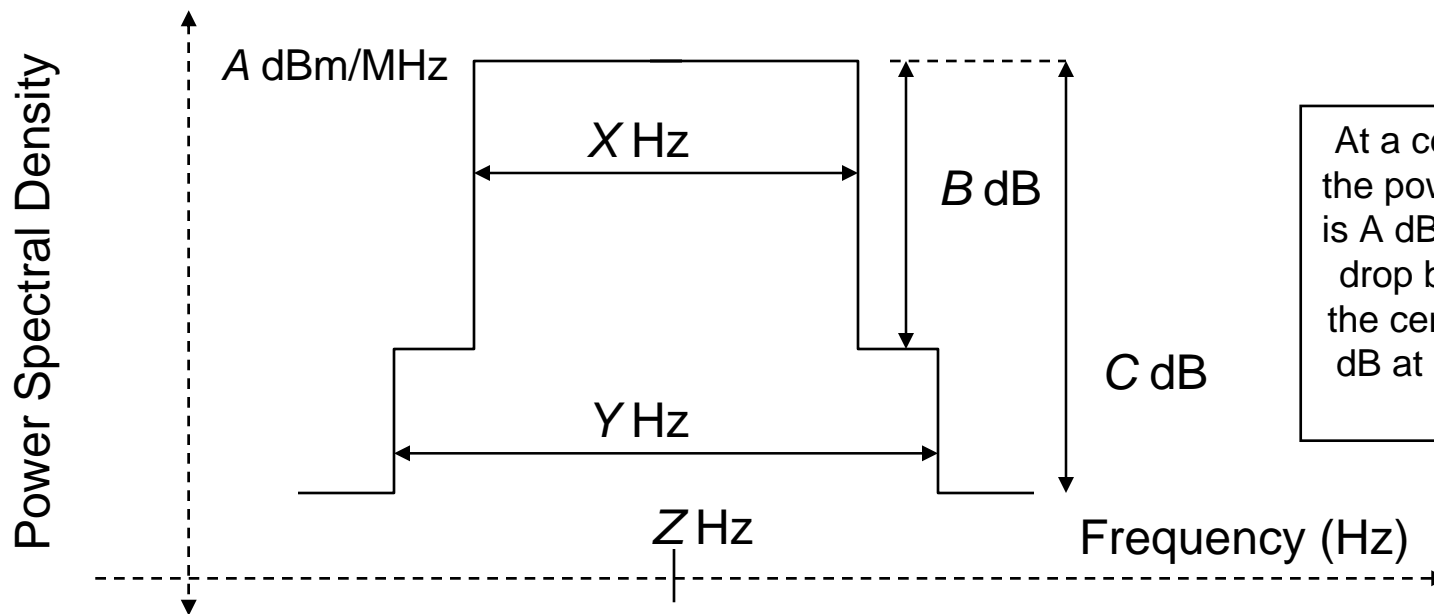

At a center frequency of Z Hz the power spectral density limit is A dBm/MHz. The PSD must drop by B dB at $\pm X/2$ Hz of the center frequency and by C dB at $\pm Y/2$ Hz of the center frequency.

Design Criteria for Pulse Spectrum



Analog and Digital Communications

- Two important spectral characteristics
 - First null bandwidth
 - Size of sidelobes
- These will determine how well the pulse fits within the mask at a given data rate
- Would like to “round off the corners” of pulses to avoid excessive spectral occupancy

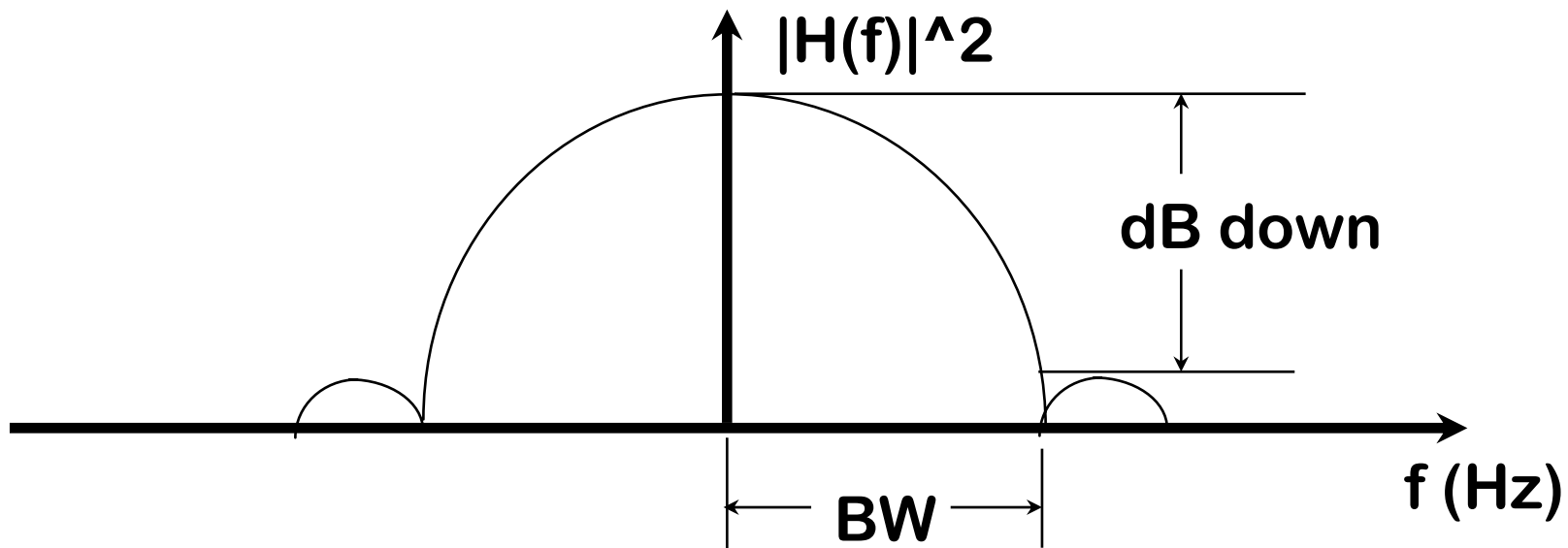

Rectangular Pulse



Analog and Digital Communications

Time Waveform

Magnitude Spectrum

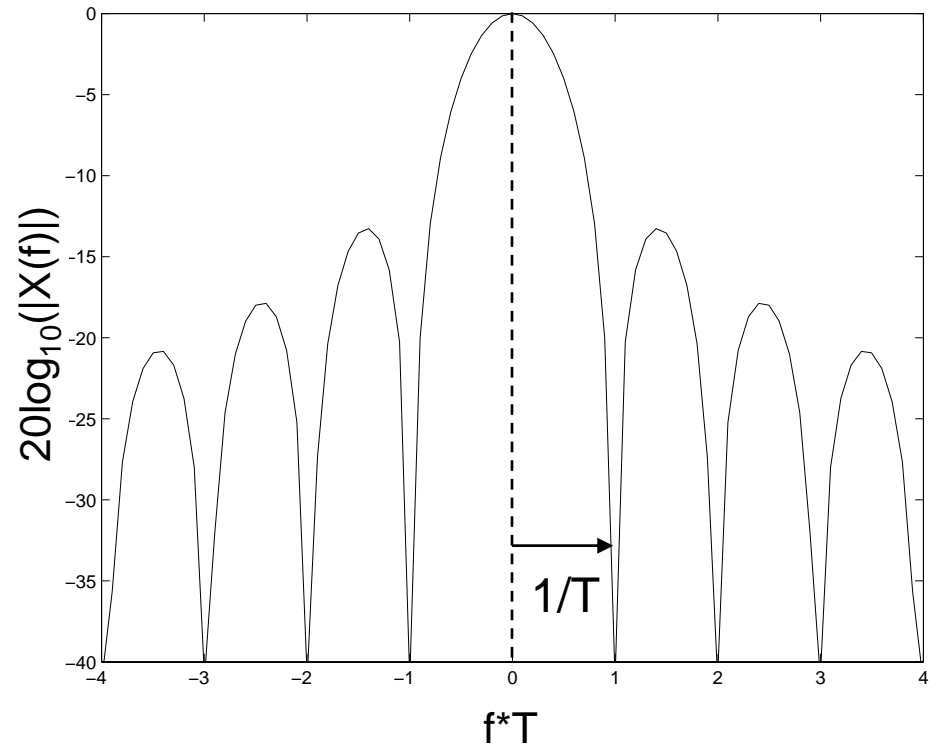
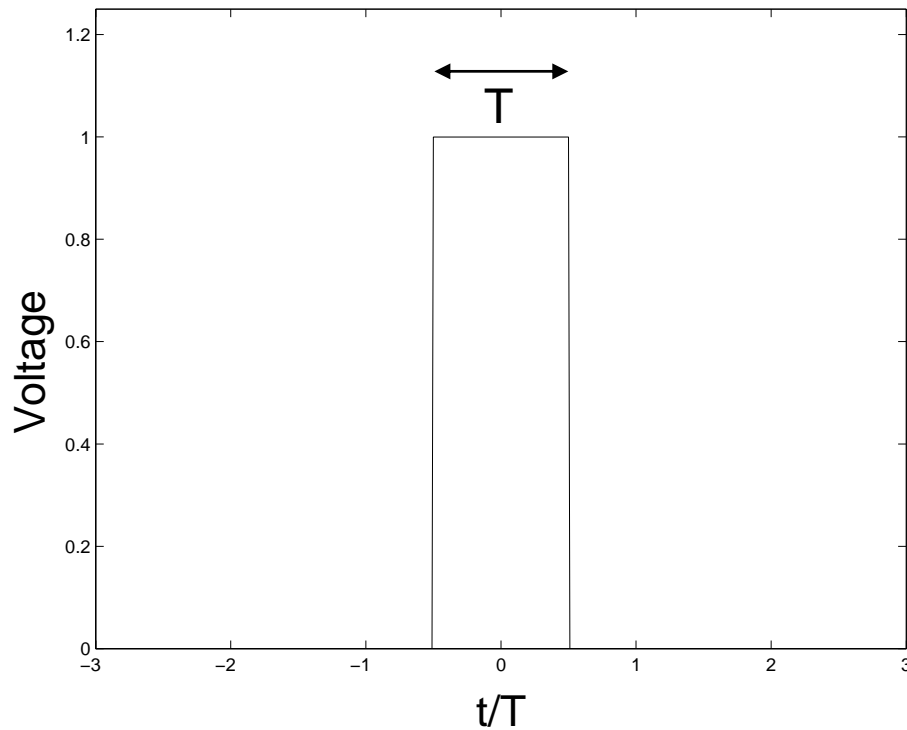

- **First Null BW: $1/T = R_s$ (symbol rate)**
- **First Sidelobe: 13.6 dB down**

Peaks equal $\frac{2}{\pi n}$

Located at $fT = \frac{2n+1}{2}$



Example Signal

Example signal

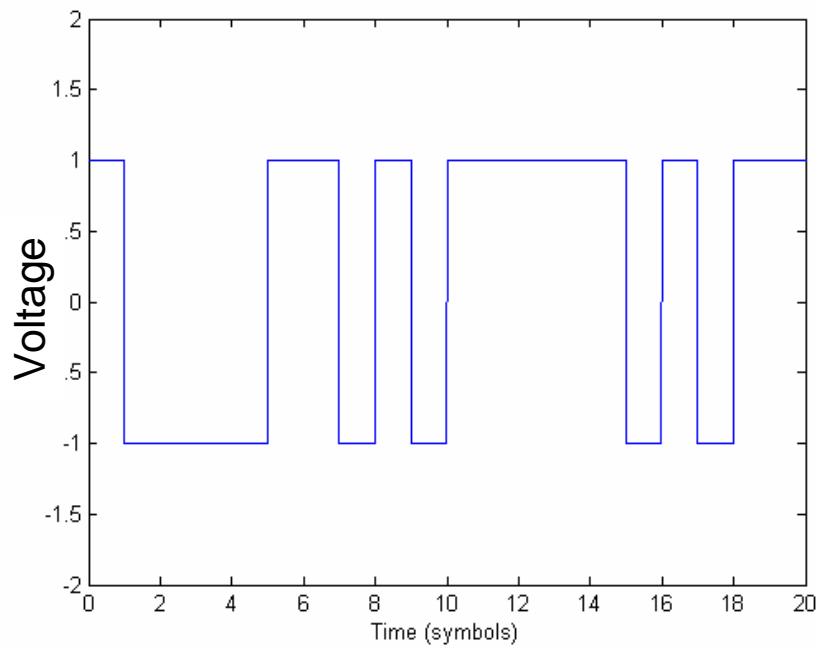

Example Spectrum

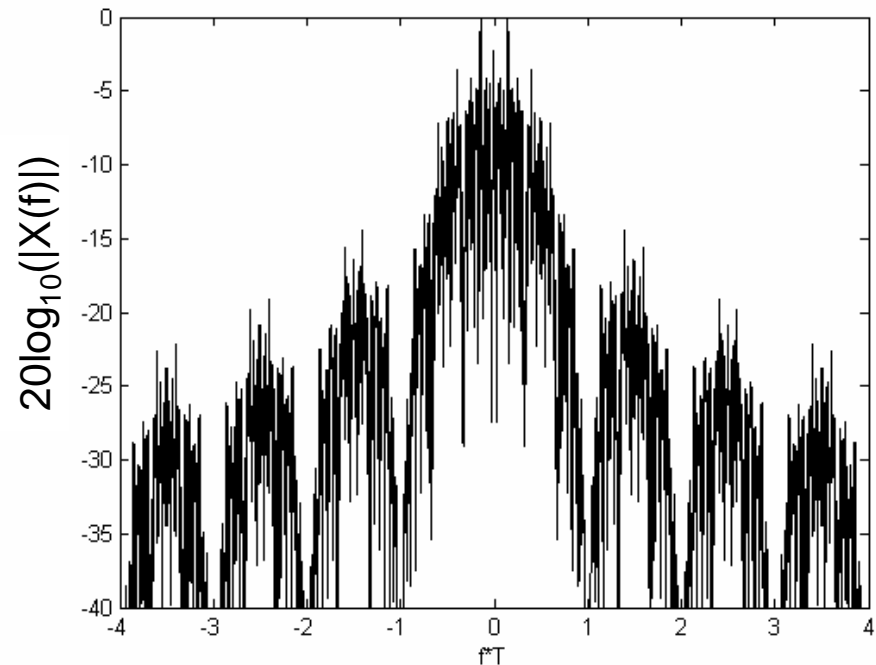

Triangular Pulse



Analog and Digital Communications

Time Waveform

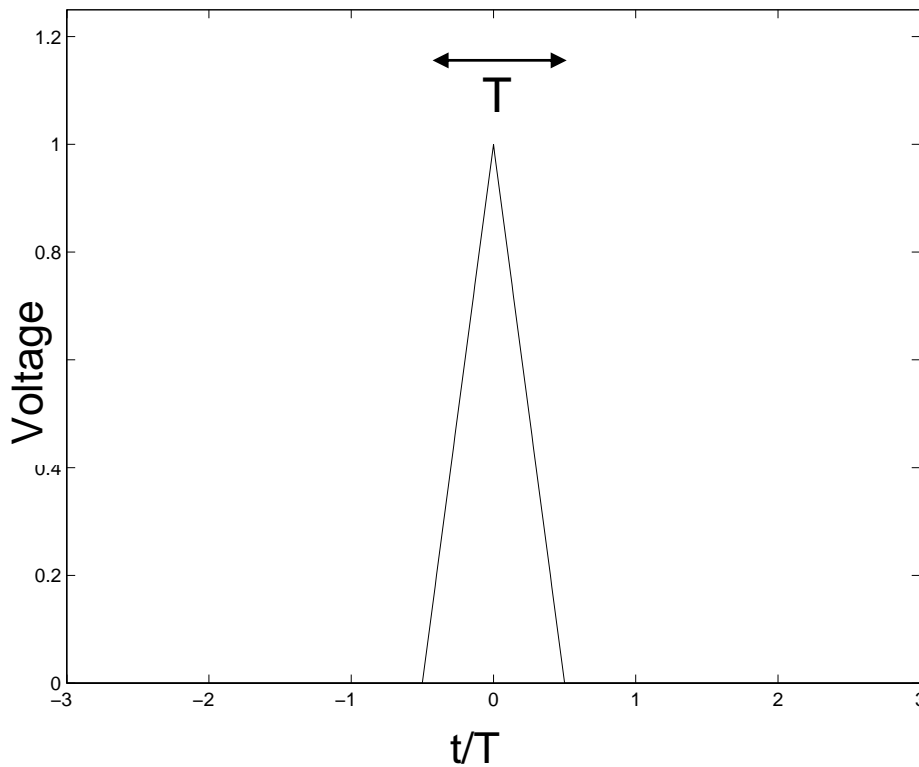

Magnitude Spectrum

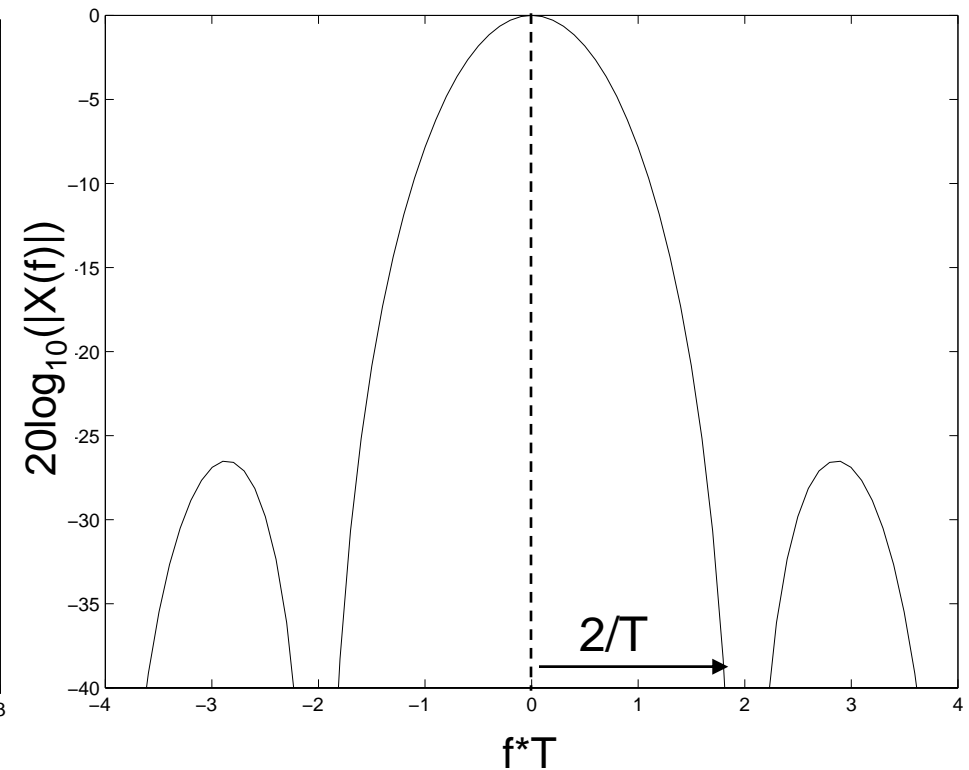

- **First Null BW: $2/T = 2R_s$**
- **First Sidelobe: 26 dB down**



Example Signal

Example signal

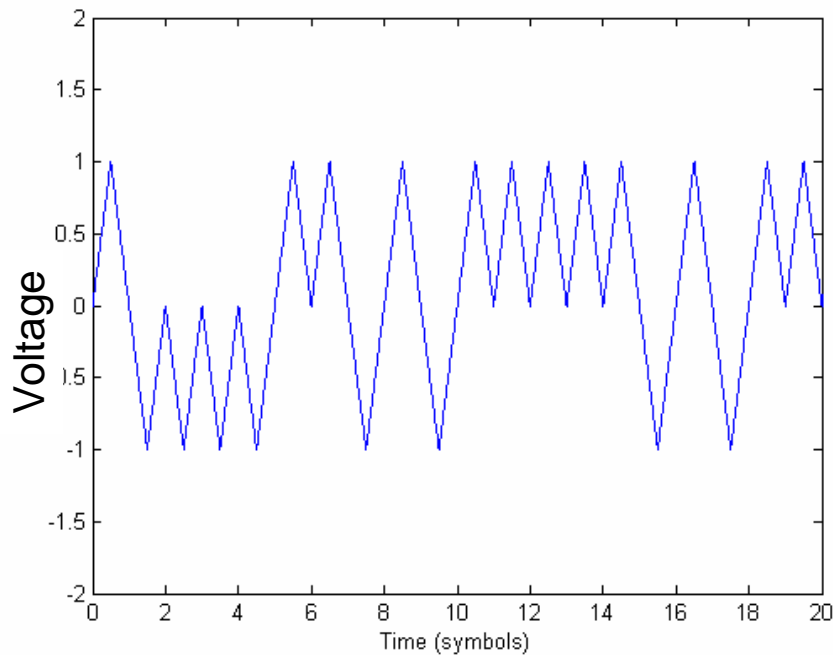

Example Spectrum

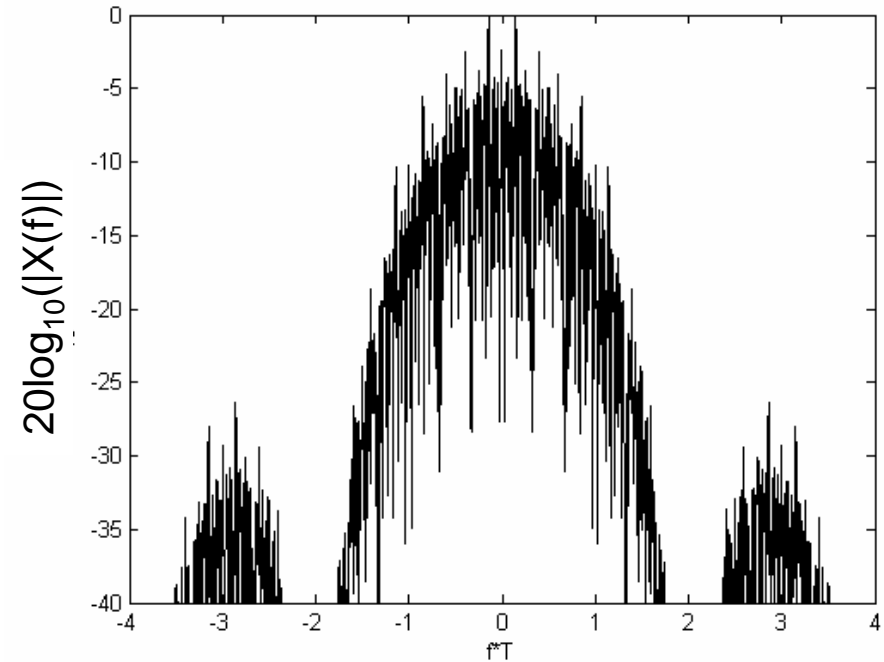

Sinusoidal Pulse Shape



Analog and Digital Communications

Time Waveform

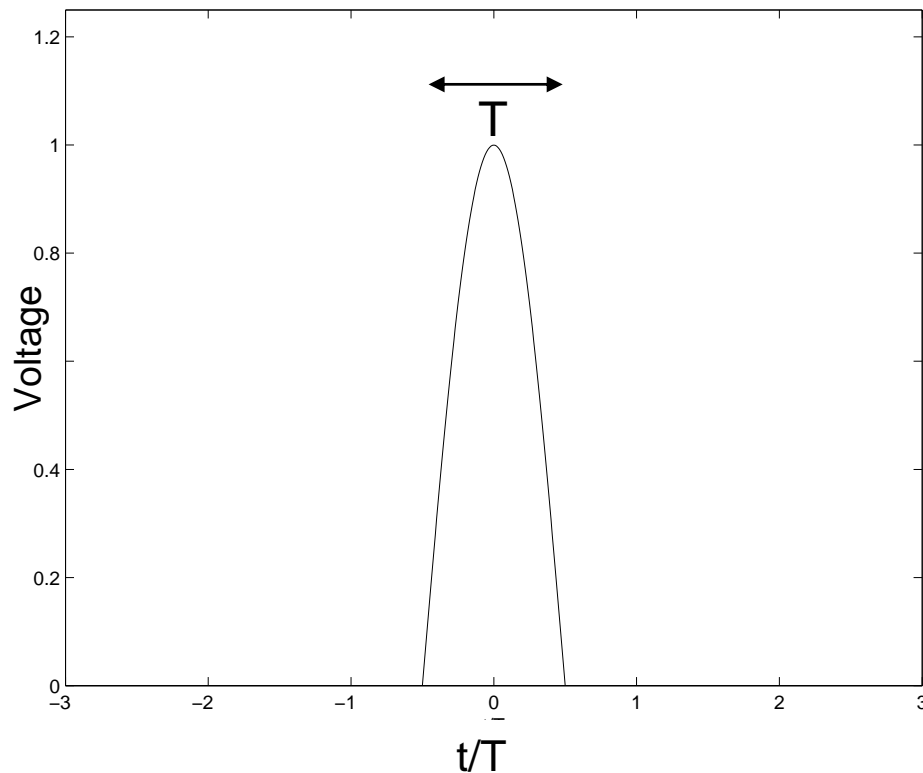

Magnitude Spectrum

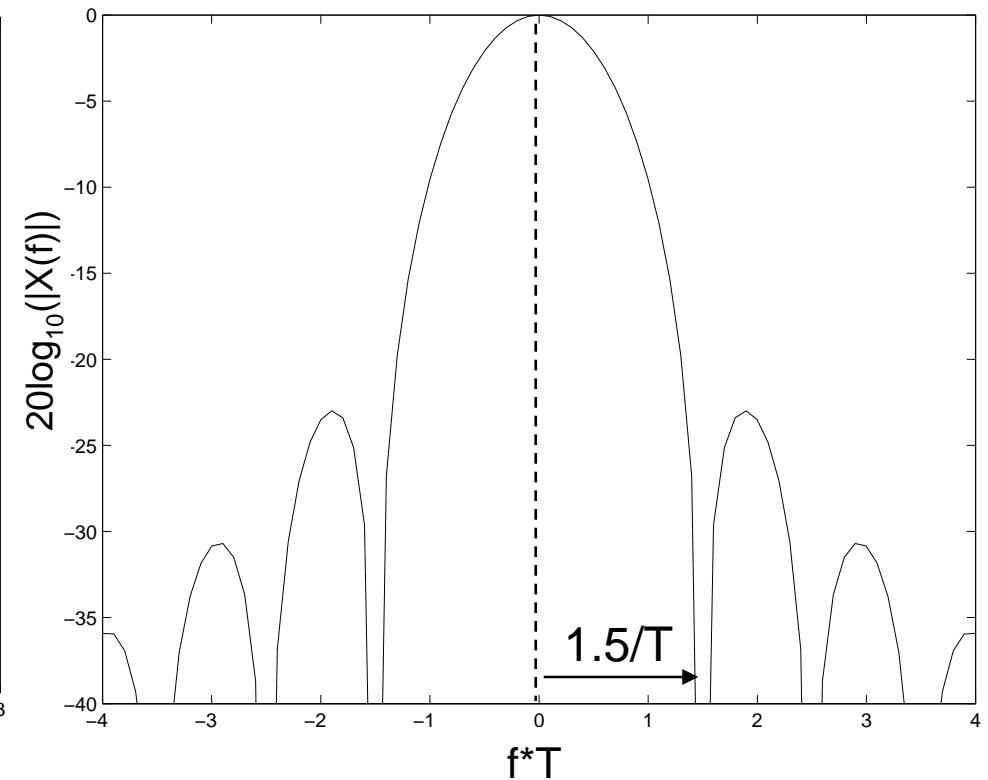

- **First Null BW: $1.5/T = 1.5R_s$**
- **First Sidelobe: 22 dB down**



Example Signal

Example signal

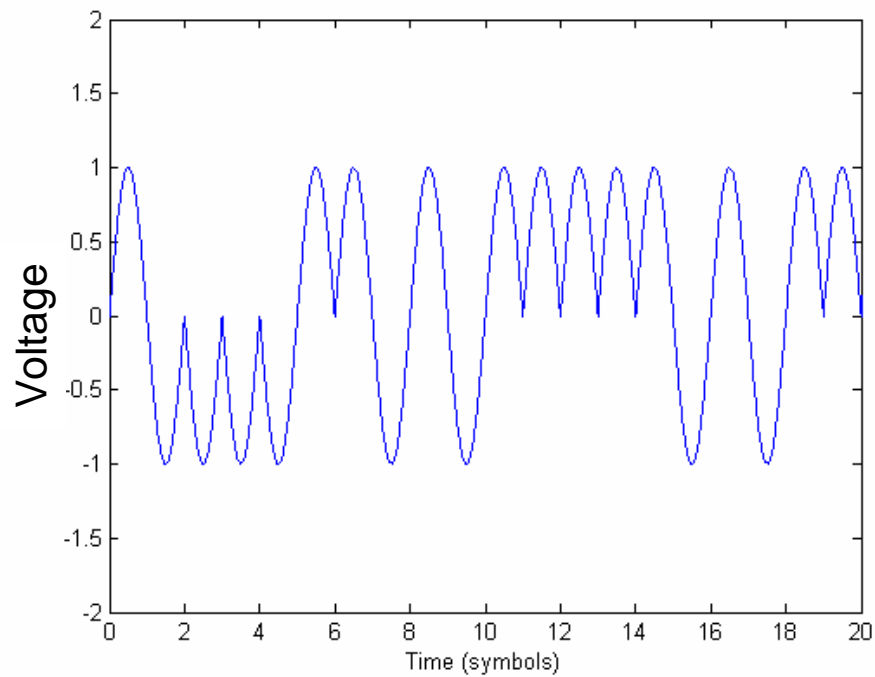

Example Spectrum

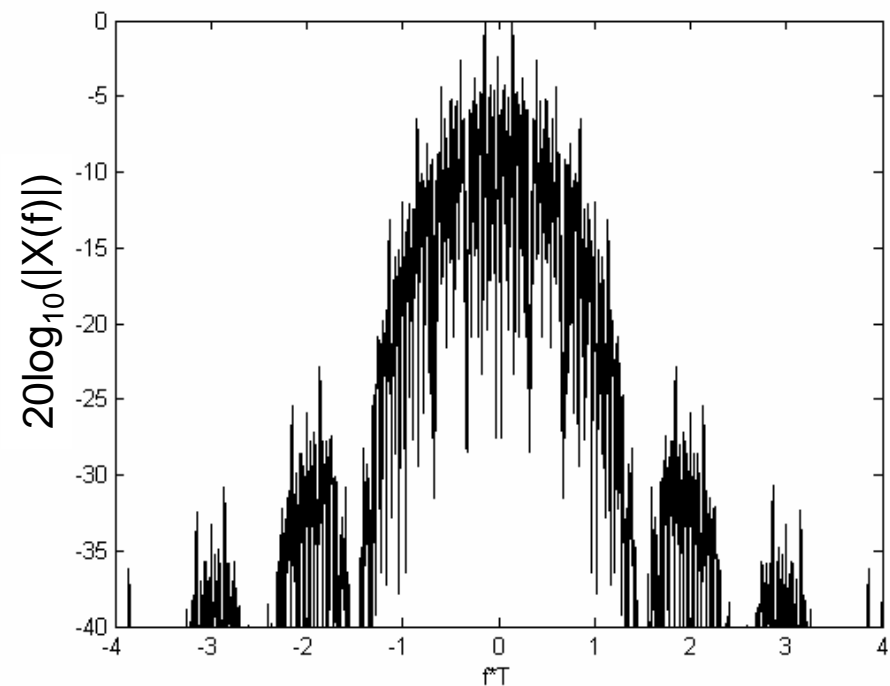

Truncated Gaussian Pulse Shape



Analog and Digital Communications

Time Waveform

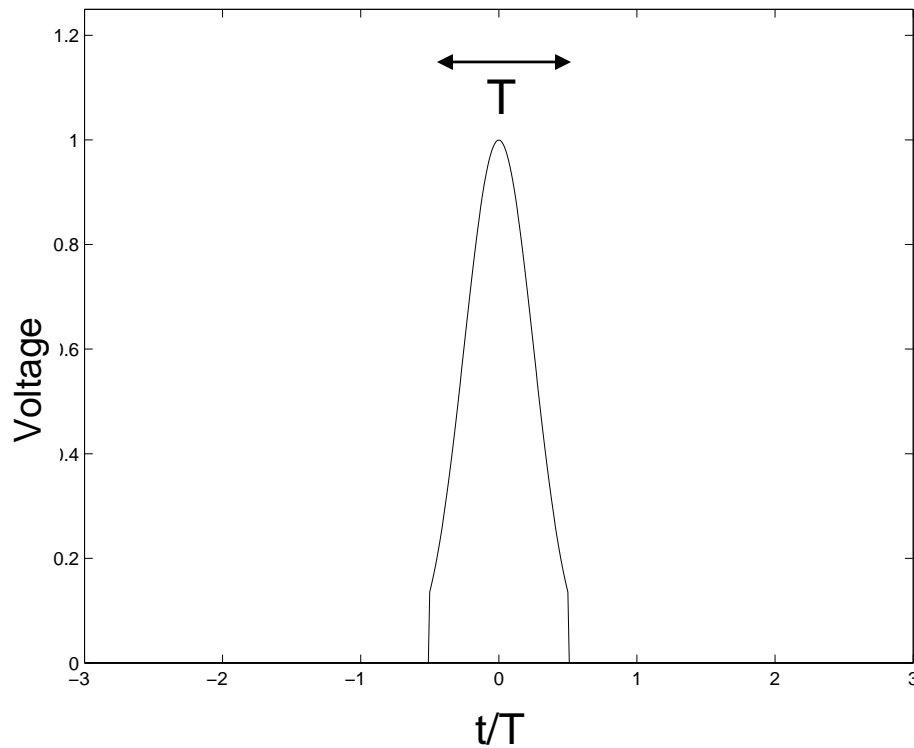

Magnitude Spectrum

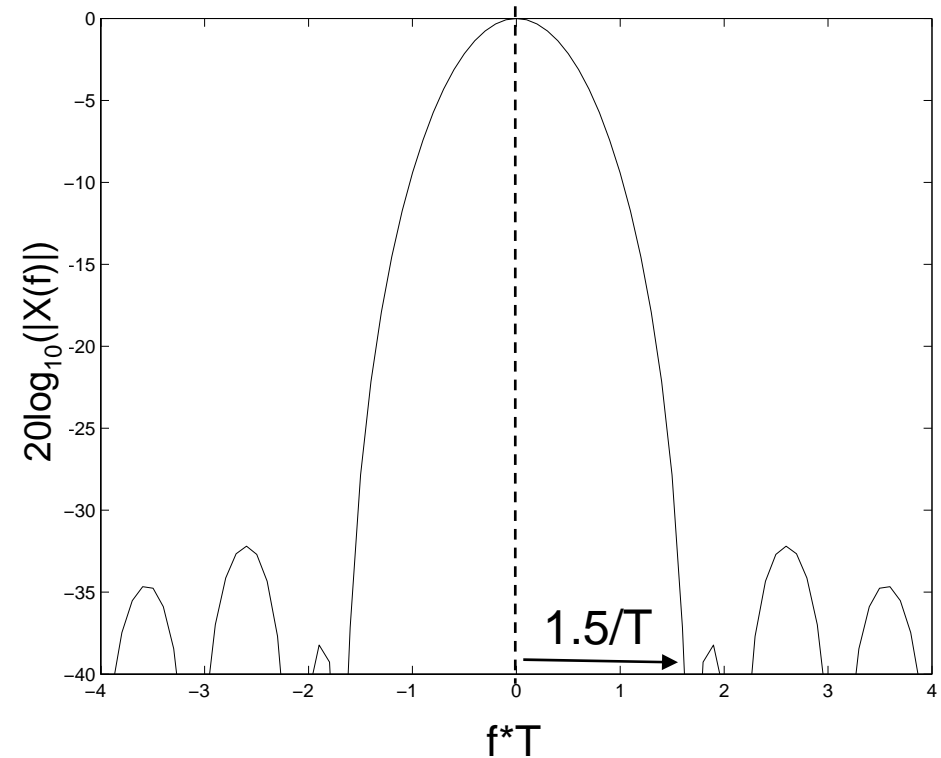

- **First Null BW: $1.5/T = 1.5R_s$**
- **Largest Sidelobe: 31 dB down**



Example Signal

Example signal

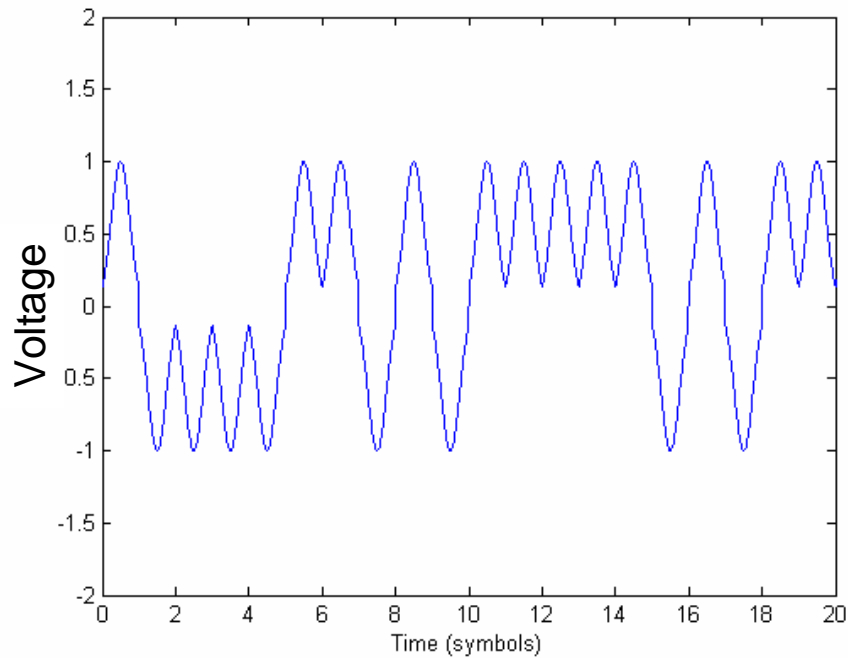

Example Spectrum

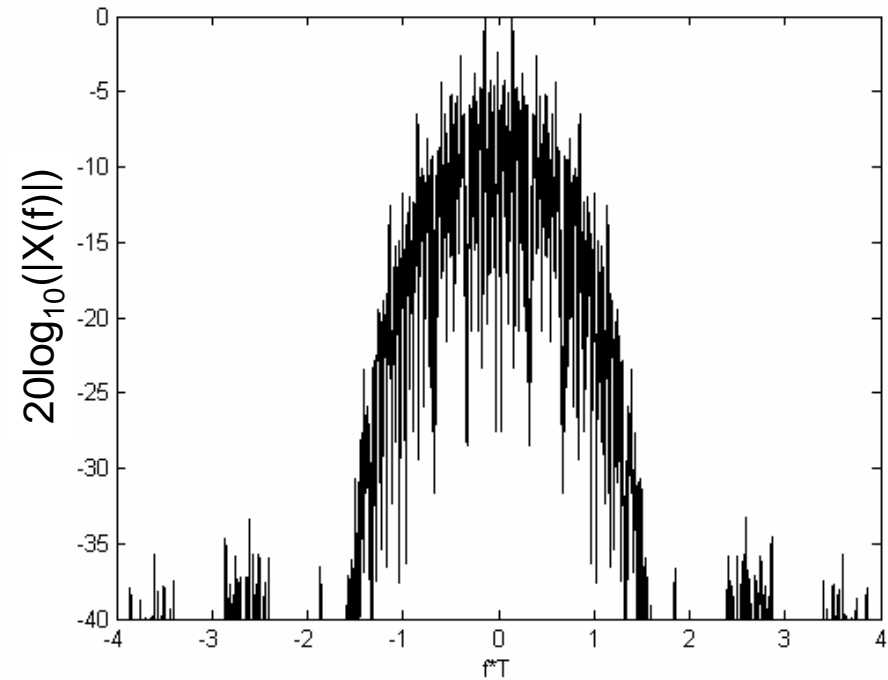

Elongating the pulse



Analog and Digital Communications

- In order to reduce the bandwidth further, we must elongate the symbols to beyond one symbol duration.
- However, if pulses overlap they may produce inter-symbol interference

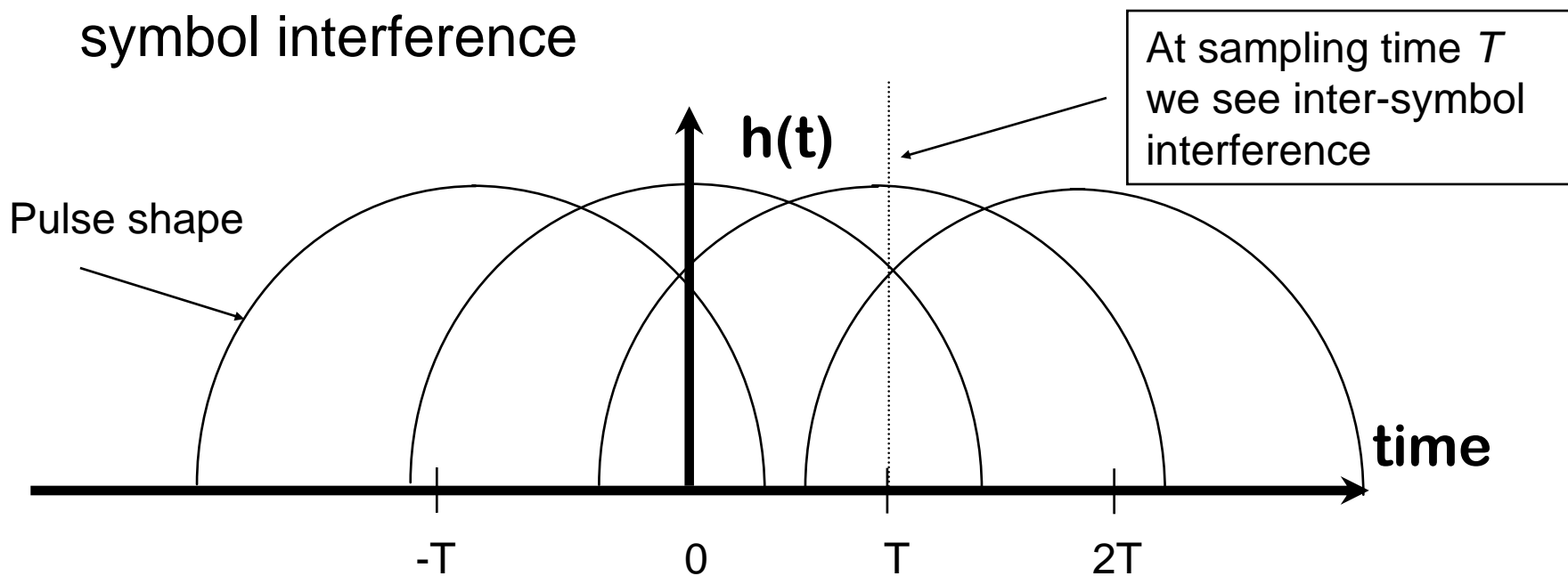



Example 11.1

- We allow the pulse to go beyond one symbol duration (exponential pulse)

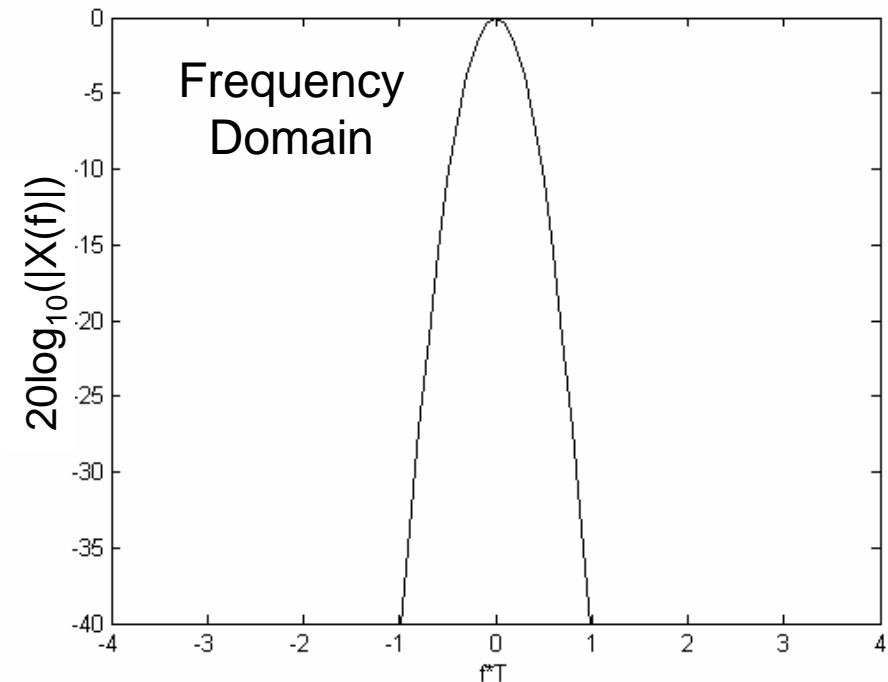
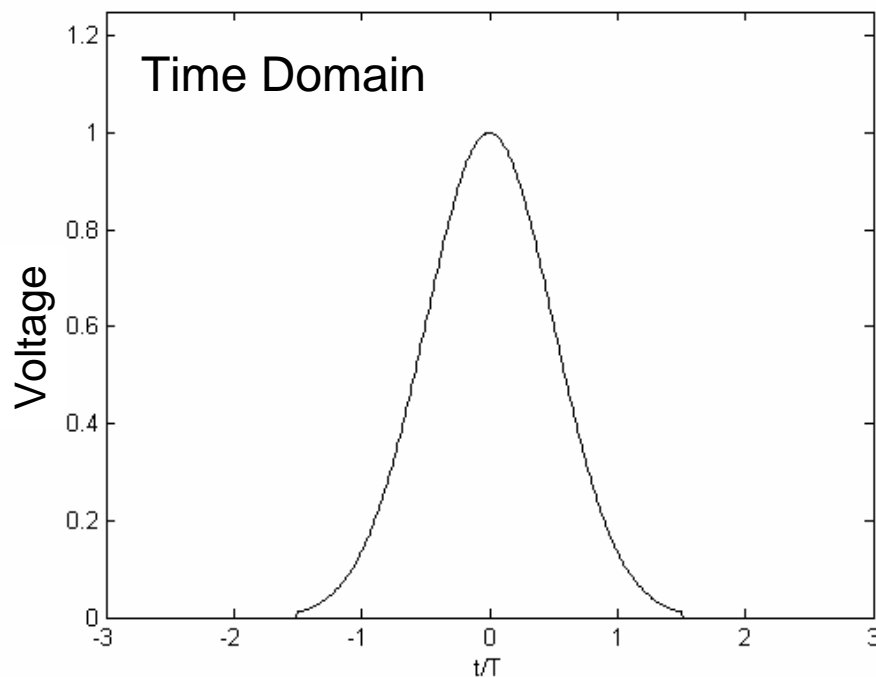

- **First Null BW: $1/T = 1R_s$**
- **First Sidelobe: > 40 dB down**



Example - continued

- Unfortunately, this leads to inter-symbol interference

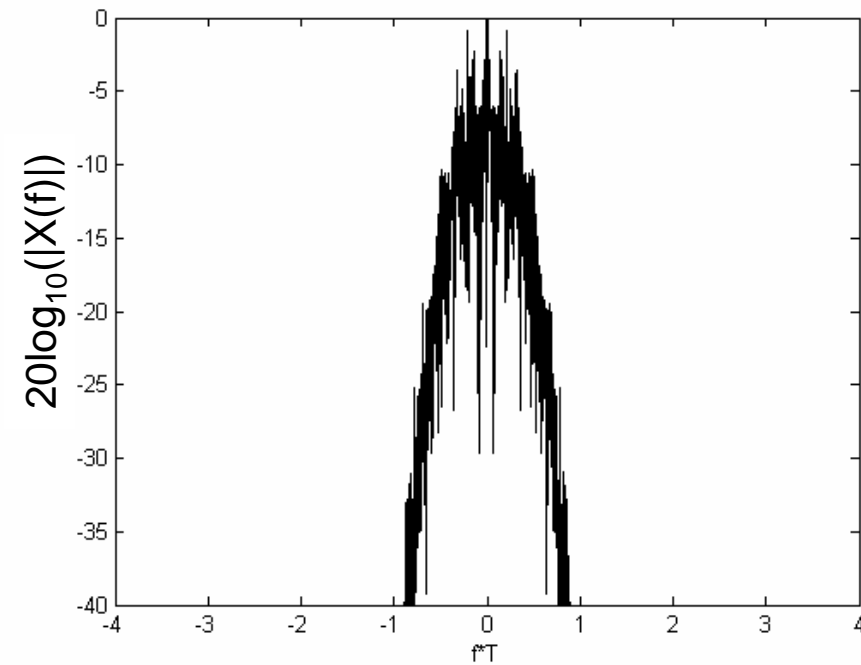
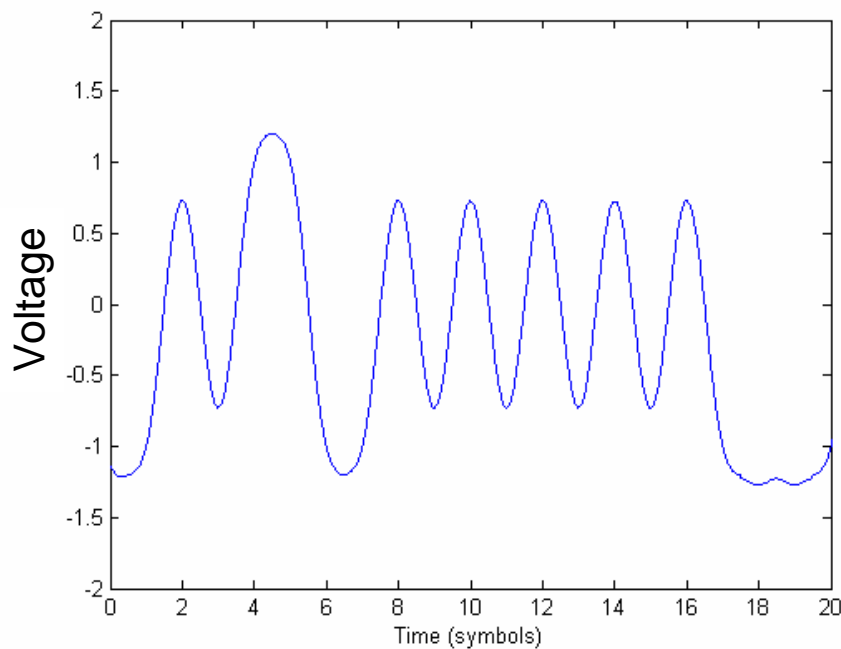

Nyquist's First Criteria for Zero ISI



Analog and Digital Communications

- Overlapping pulses will not cause inter-symbol interference if they have zero amplitude *at the time we sample the signal*.
- Mathematically we desire:

$$h(kT_s) = \begin{cases} C, & k = 0 \\ 0, & k \neq 0 \end{cases}$$

- where $h(t)$ is the pulse shape, k is an integer and T_s is one symbol duration
- What is one pulse that we have examined that exhibits this property?
 - A Sinc pulse



Nyquist's First Criteria for Zero ISI

- This requirement is equivalent to having a transfer function

$$H(f) = \begin{cases} \text{rect}\left(\frac{f}{2B_o}\right) + Y(f) & |f| < 2B_o \\ 0 & \text{else} \end{cases}$$

where $B_o = R_s/2$ (i.e., $1/2$ the symbol rate) and $Y(f)$ is a real function that is even symmetric about $f=0$ and odd symmetric about $f=B_o$.

$$\begin{array}{l} Y(-f) = Y(f) \quad |f| < 2B_o \\ Y(-f + B_o) = -Y(f + B_o) \quad |f| < B_o \end{array}$$

See Appendix
for proof

Sinc pulses



Analog and Digital Communications

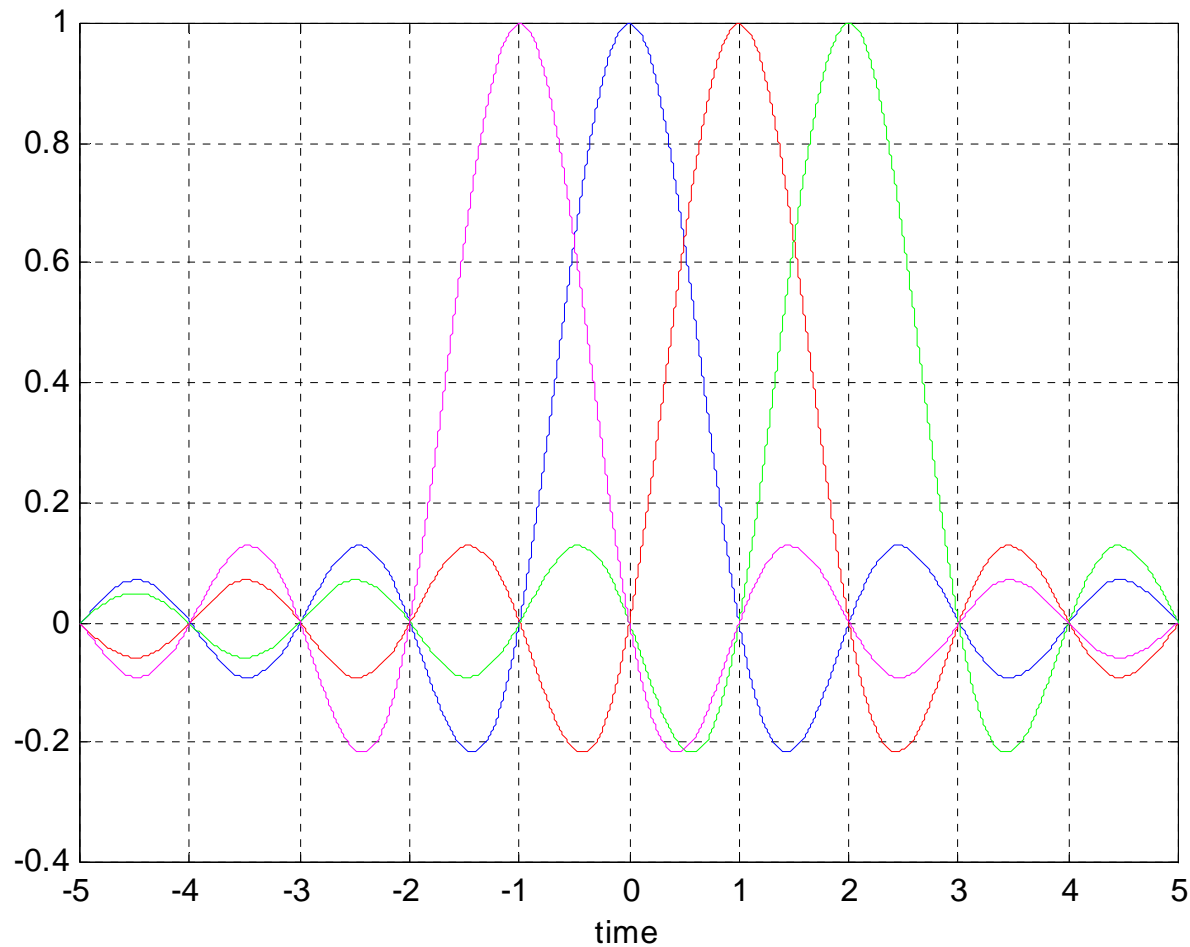

Note that at sampling times adjacent pulses equal zero

No Inter-Symbol Interference (ISI) if we are using sinc pulses.



Nyquist Filters

- Use of $\text{sinc}(t/T_o)$ pulses does allow for zero ISI, however, it require filters in frequency that are impossible to implement (“brick wall filters”) since they are non-causal.
 - We can make them causal by truncating the pulse and adding a delay
- These pulses have the minimum bandwidth possible ($B = B_o = R/2$).
- We can use (*modestly*) more practical filters and still satisfy Nyquist’s zero ISI criteria if we allow the use of more bandwidth
- One set of such filters are *Raised-Cosine filters* or in the time domain *Raised-Cosine pulses*

Raised Cosine Pulse Family - Satisfies the Nyquist Criteria



- Frequency Domain:

$$H(f) = \begin{cases} \frac{\sqrt{E}}{2B_o} & 0 \leq |f| < f_1 \\ \frac{1}{2} \frac{\sqrt{E}}{2B_o} \left[1 + \cos \left(\frac{\pi(|f| - f_1)}{2(B_o - f_1)} \right) \right] & f_1 \leq |f| \leq 2B_o - f_1 \\ 0 & |f| > 2B_o - f_1 \end{cases}$$

- $B = 2B_o - f_1$ is the absolute bandwidth of the filter
- B_o and f_1 are related through α which is termed the roll-off factor

$$\alpha = 1 - \frac{f_1}{B_o}$$

- Time Domain: $h(t) = F^{-1}\{H(f)\} = \sqrt{E} \left[\frac{\sin(2\pi B_o t)}{2\pi B_o t} \right] \cdot \left[\frac{\cos(2\pi \alpha B_o t)}{1 - (4\alpha B_o t)^2} \right]$

$$= \sqrt{E} \operatorname{sinc}(2B_o t) \cdot \left[\frac{\cos(2\pi \alpha B_o t)}{1 - (4\alpha B_o t)^2} \right]$$

Spectrum of Raised Cosine Pulse



Analog and Digital Communications

- $\alpha = 0$ corresponds to $\text{sinc}(\)$ function and “brick wall filter”

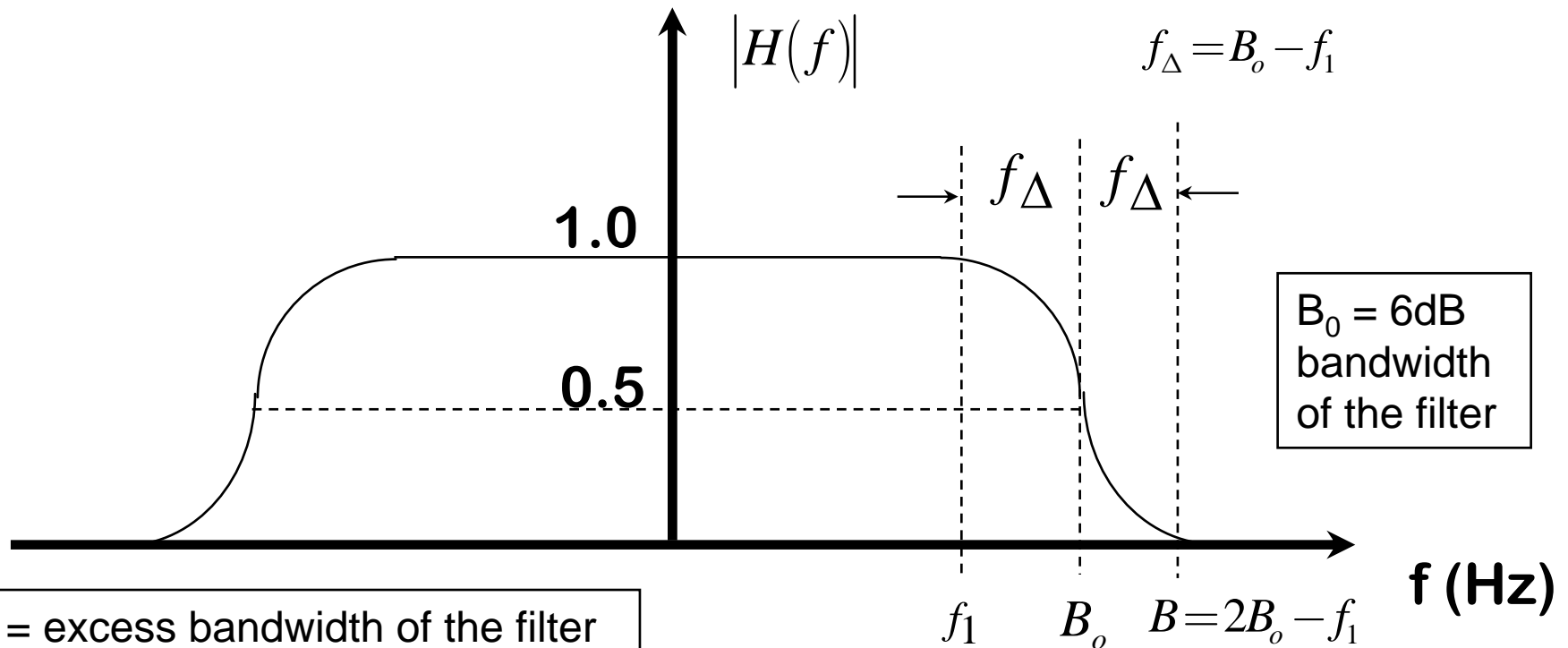

- f_Δ = excess bandwidth of the filter since it represents the bandwidth beyond the minimum.
- As α increases, f_Δ increases

RM Buehrer
Virginia Tech
Fall 2007

$$\alpha = 0 \longrightarrow B = B_0 = R_s / 2$$

$$\alpha = 1 \longrightarrow B = 2B_0 = R_s$$

Pulse Design for No ISI

Raised Cosine ($\alpha=0$)



Analog and Digital Communications

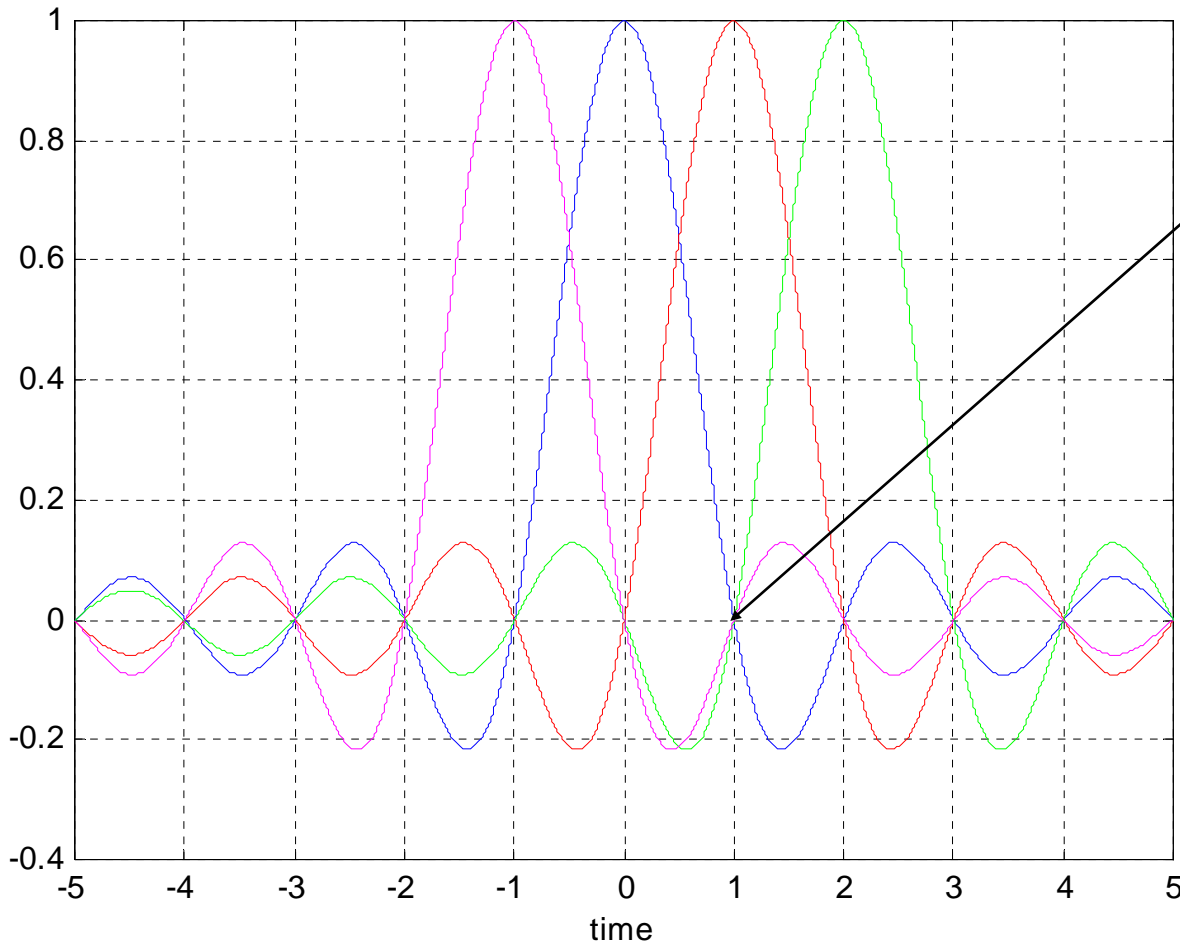

Note that at sampling times adjacent pulses equal zero

No Inter-Symbol Interference (ISI) if we are using RC pulses.

Note that RC pulses with $\alpha = 0$ are sinc pulses

Raised Cosine Pulse - Time Domain

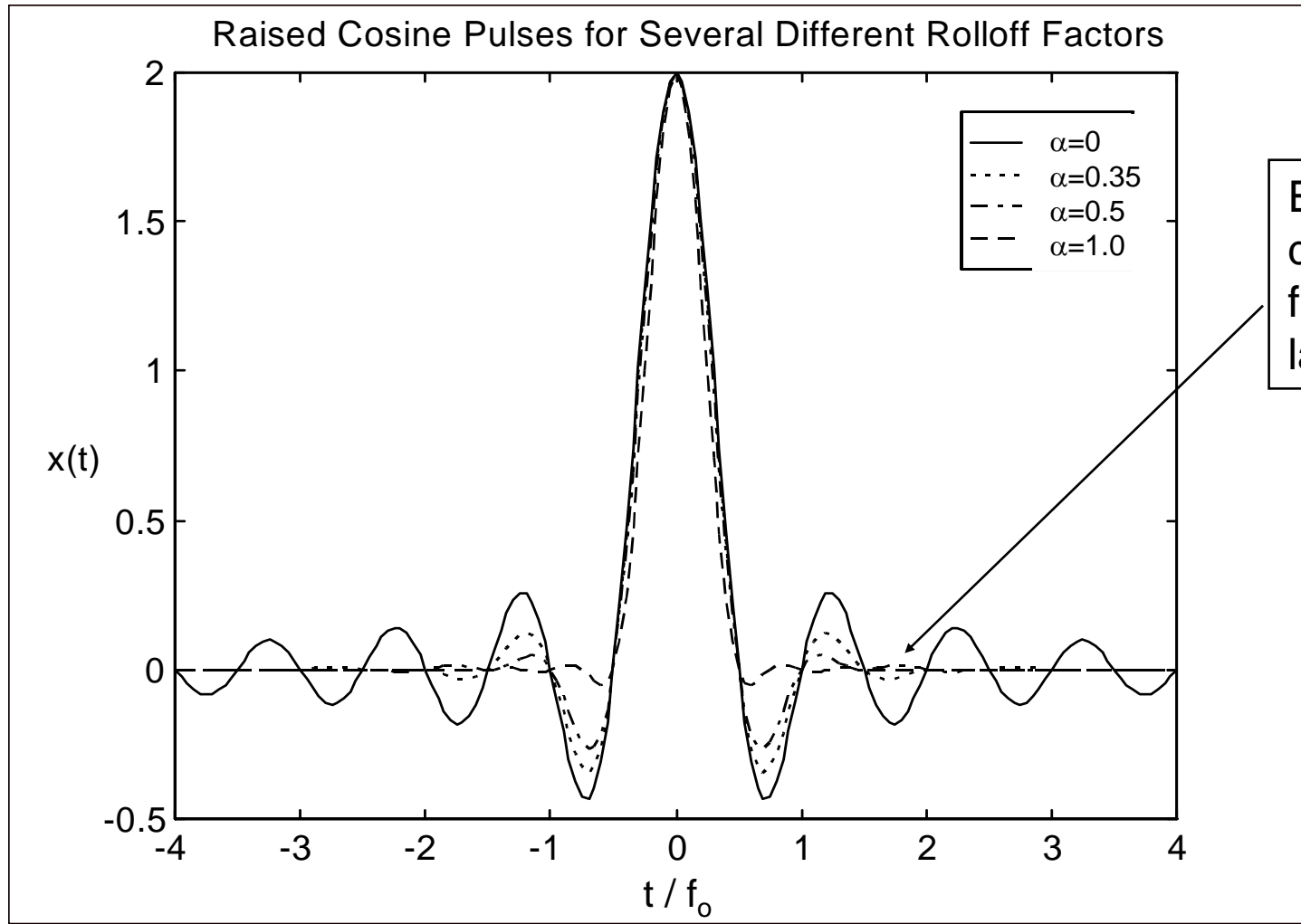

Envelope decays faster with larger α

$$T_s = 1/2B_o$$

Raised Cosine Pulse - Frequency Domain



Analog and Digital Communications

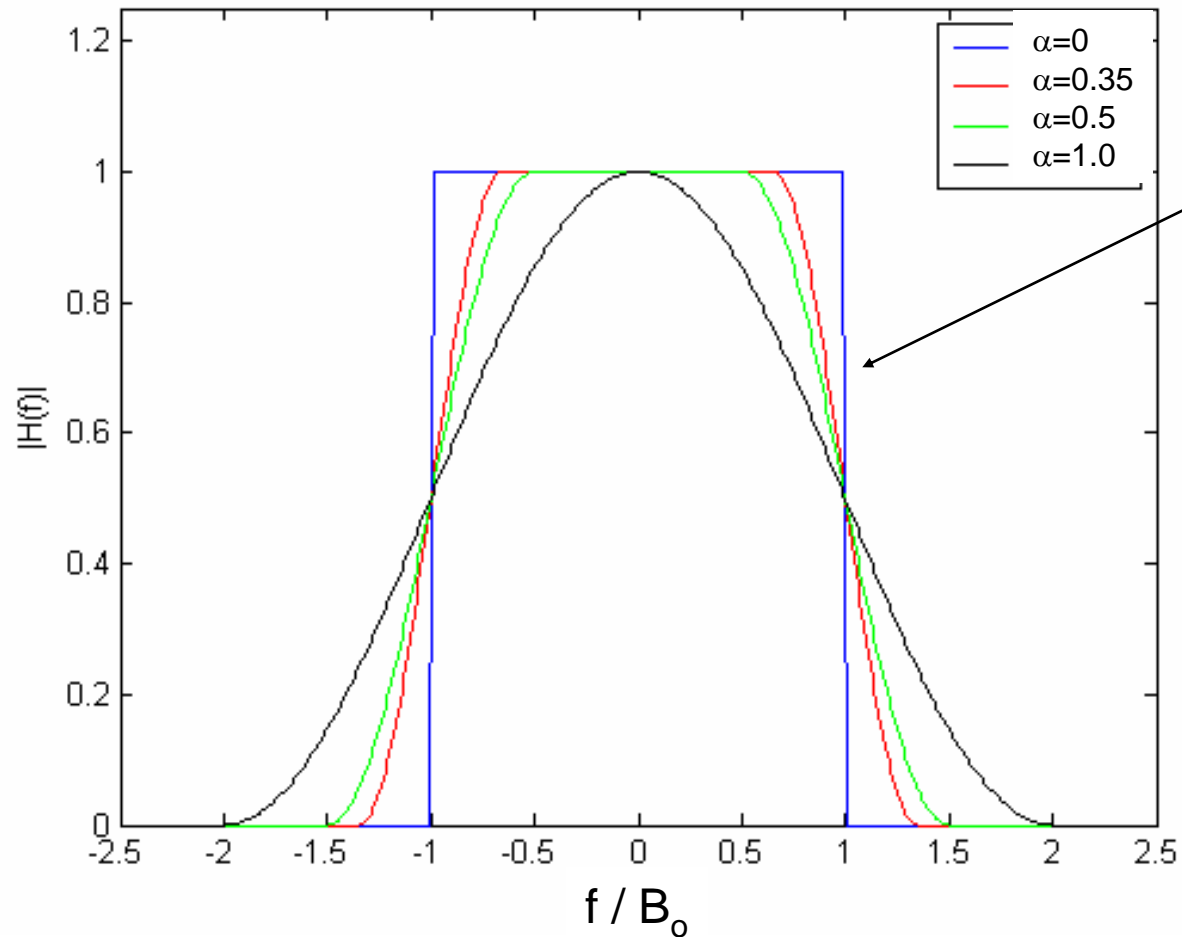

Increasing α increases bandwidth

Note: $B_0 = R_s/2$

$B_{\min} = B_0 = R_s/2$

$B_{\max} = 2B_0 = R_s$

Bandwidth of Raised Cosine Pulses



Analog and Digital Communications

- For PCM system:

$$B = (1 + \alpha) \cdot f_s \cdot n / 2 \text{ Hz}$$

- $0 \leq \alpha \leq 1$ is a parameter called “roll-off factor”
- Special cases:
 - $\alpha = 0$ is just a *sinc(.)* function
 - $\alpha = 1$ is the largest possible value
 - $\alpha = 0.35$ was used in the old U.S. Digital Cellular (IS-54/136) standard

Examples



Analog and Digital Communications

Time Domain

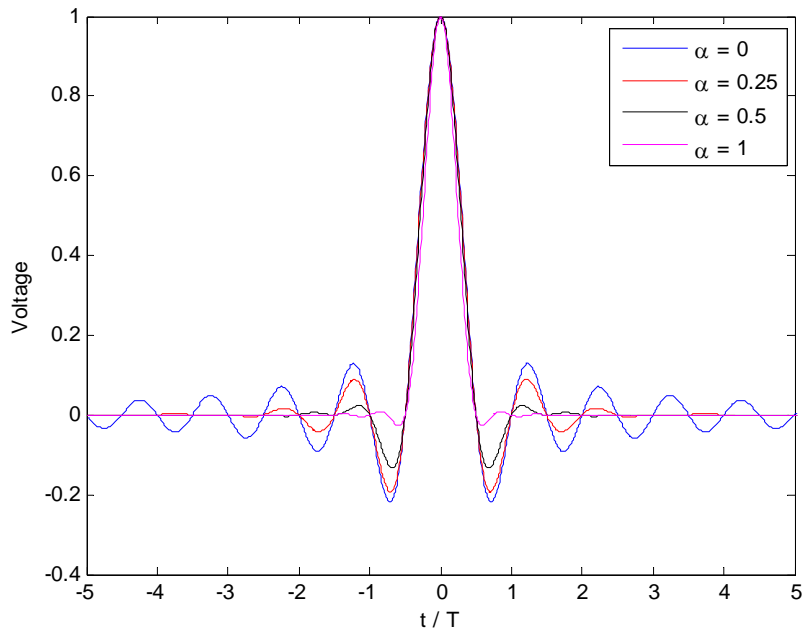

Frequency Domain

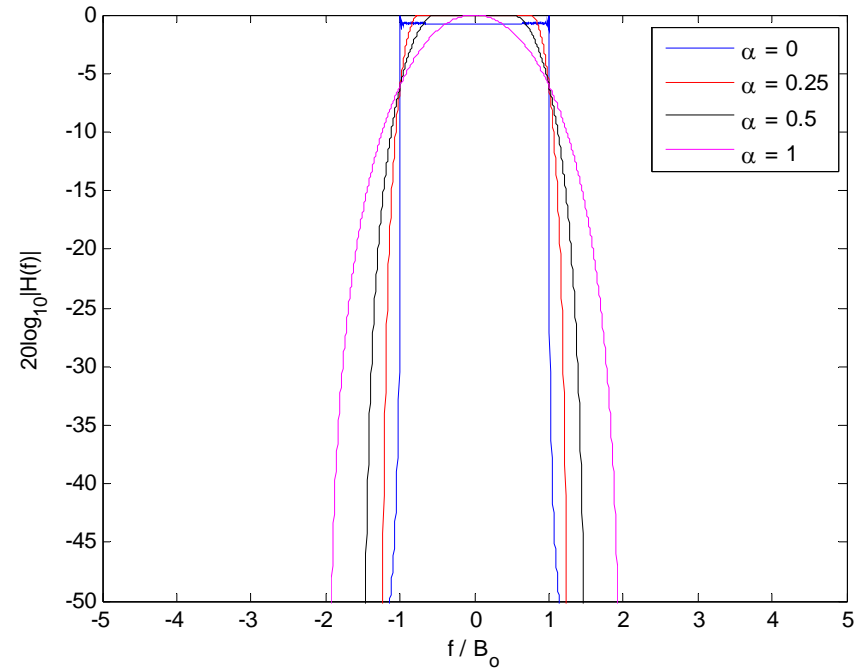

In class drill



Analog and Digital Communications

Implementation of Raised Cosine Pulse



Analog and Digital Communications

- Can be digitally implemented with an FIR filter
- Analog filters such as Butterworth filters may approximate the tight shape of this spectrum
- Practical pulses must be truncated in time
 - Truncation leads to sidelobes - even in RC pulses
 - The larger the value of α , the less effect that a given truncation length has.
- Sometimes a “square-root” raised cosine spectrum is used when identical filters are implemented at transmitter and receiver
 - We will discuss this more when we talk about “matched filtering”

Truncated Raised Cosine Pulses



Analog and Digital Communications

- Truncating raised cosine pulse to finite duration results in some side-lobes

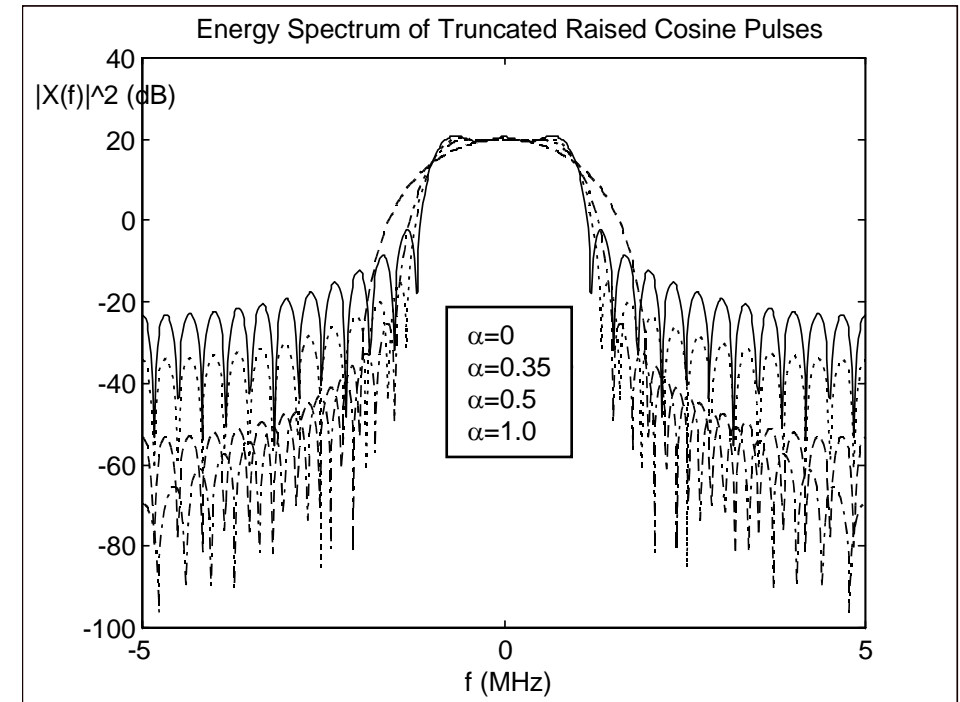
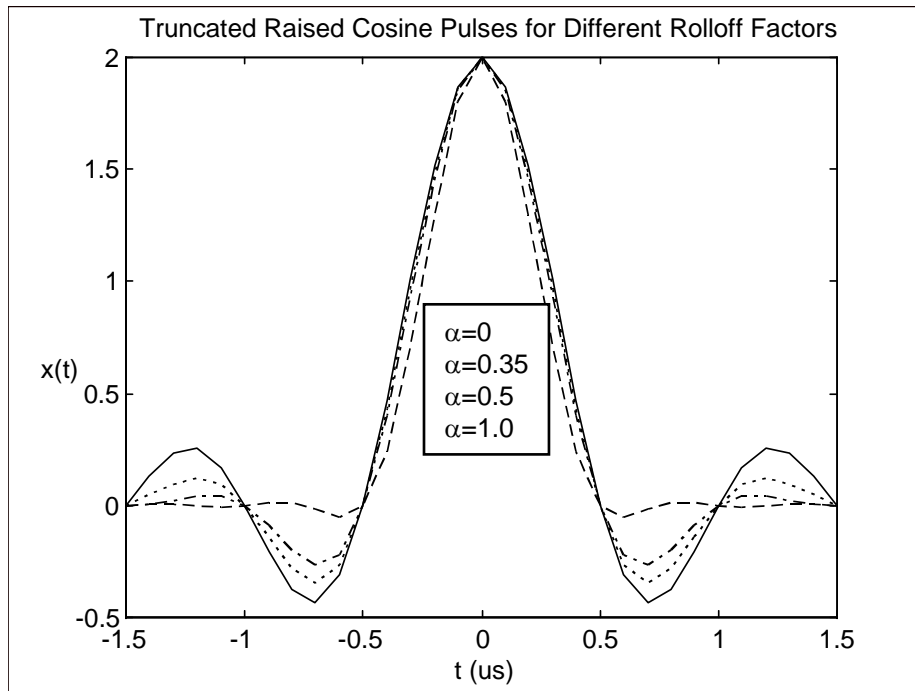

Example



Analog and Digital Communications

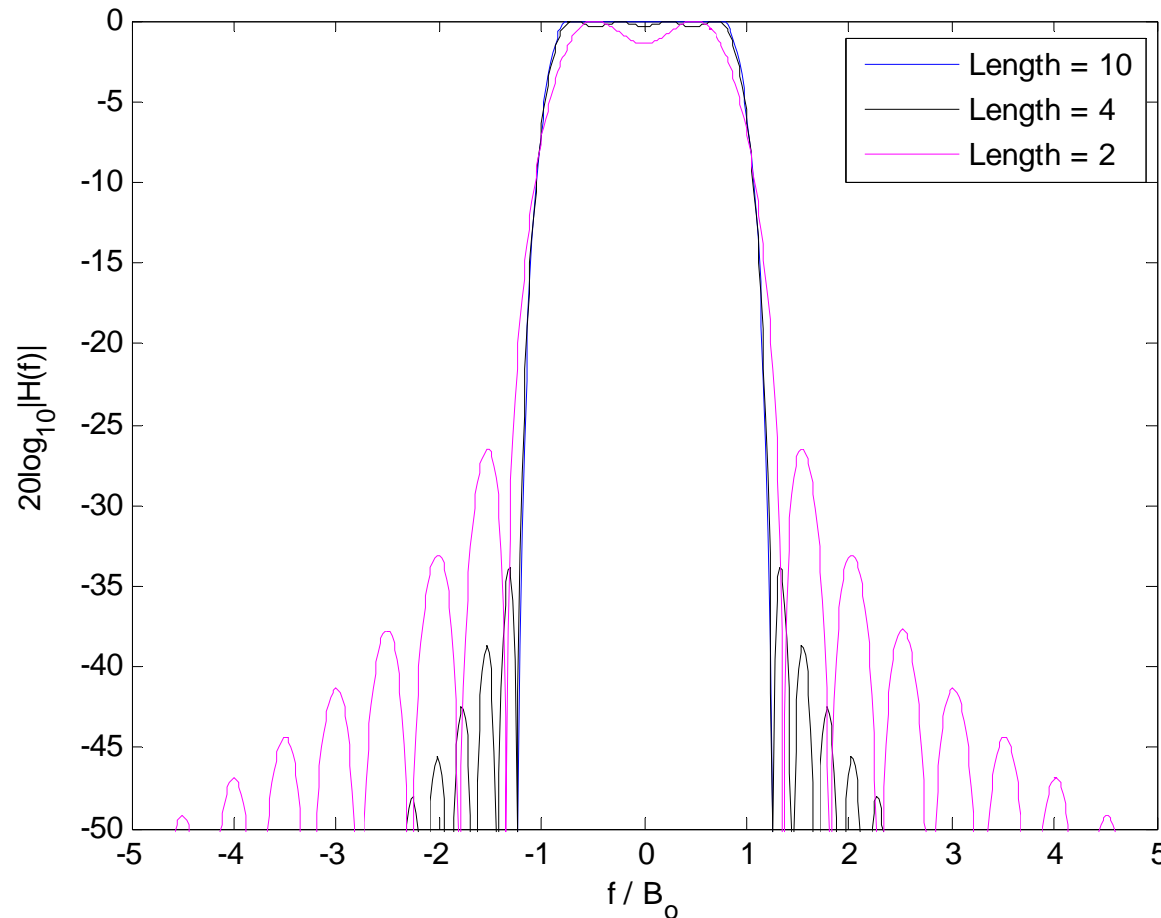

- $\alpha = 0.25$
- Truncated to 10, 4, and 2 symbols
- For 10-symbol long approximation, we see no side-lobes within 50dB
- As truncation length gets smaller, side-lobes rise
- Larger truncation length requires larger delay to make pulse causal.



Conclusions

- Reducing the bandwidth of the transmit signal is desirable to improve spectral efficiency (i.e., get the most bits/sec in the smallest bandwidth)
- Elongating pulses is a good way to reduce bandwidth
 - Elongating pulses indiscriminately will introduce ISI
- Intelligent pulse design can reduce bandwidth without this penalty
 - Nyquist Criterion
 - Sinc pulse and Raised Cosine pulse satisfy Nyquist Criterion
- Channel conditions can also reduce bandwidth further resulting in channel-induced ISI
 - We will discuss this more next time

ECE4634

Appendix

Proof of Nyquist Filter Frequency Domain Characteristics



Analog and Digital Communications



Nyquist's First Criteria for Zero ISI

- Zero ISI in the time domain is equivalent to having a transfer function

$$H(f) = \begin{cases} \text{rect}\left(\frac{f}{2B_o}\right) + Y(f) & |f| < 2B_o \\ 0 & \text{else} \end{cases}$$

where $B_o = R_s/2$ (i.e., $1/2$ the symbol rate) and $Y(f)$ is a real function that is even symmetric about $f=0$ and odd symmetric about $f=B_o$.

$$\begin{array}{l} Y(-f) = Y(f) \quad |f| < 2B_o \\ Y(-f + B_o) = -Y(f + B_o) \quad |f| < B_o \end{array}$$

Proof



$$\begin{aligned}
 h(t) &= \int_{-2B_o}^{-B_o} Y(f)e^{j\omega t} df + \int_{-B_o}^{B_o} (1+Y(f))e^{j\omega t} df + \int_{B_o}^{2B_o} Y(f)e^{j\omega t} df \\
 &= \int_{-B_o}^{B_o} e^{j\omega t} df + \int_{-2B_o}^{2B_o} Y(f)e^{j\omega t} df \\
 &= 2B_o \left(\frac{\sin(2\pi B_o t)}{2\pi B_o t} \right) + \int_{-2B_o}^0 Y(f)e^{j\omega t} df + \int_0^{2B_o} Y(f)e^{j\omega t} df
 \end{aligned}$$

Via a change of variables:

$$\begin{aligned}
 h(t) &= 2B_o \left(\frac{\sin(2\pi B_o t)}{2\pi B_o t} \right) + e^{-j2\pi B_o t} \int_{-B_o}^{B_o} \boxed{f_1=f+B_o} Y(f_1 - B_o) e^{j2\pi f_1 t} df_1 + e^{-j2\pi f_o t} \int_{-B_o}^{B_o} \boxed{f_1=f-B_o} Y(f_1 + B_o) e^{j2\pi f_1 t} df_1 \\
 &= 2B_o \left(\frac{\sin(2\pi B_o t)}{2\pi B_o t} \right) + j2 \sin(2\pi B_o t) \int_{-B_o}^{B_o} Y(f_1 + B_o) e^{j2\pi f_1 t} df_1
 \end{aligned}$$

Due to $Y(f_1 - B_o) = -Y(f_1 + B_o)$



Proof (cont.)

$$h(t) = 2B_o \left(\frac{\sin(2\pi B_o t)}{2\pi B_o t} \right) + j2 \sin(2\pi B_o t) \int_{-B_o}^{B_o} Y(f_1 + B_o) e^{j2\pi f_1 t} df_1$$

We can see that the above equation is zero at $t=n/(2B_o)$ for n not equal to zero.

One pulse shape that satisfies this equation is

$$H(f) = \begin{cases} \text{rect}\left(\frac{f}{2B_o}\right) & |f| < 2B_o \\ 0 & \text{else} \end{cases} \quad \boxed{Y(f)=0}$$

Or $\text{sinc}(t/T_o)$ in the time domain