

# ECE4634

## Digital Communications

### Fall 2007

---

Instructor: R. Michael Buehrer  
Lecture # 21 – Introduction to  
Signal-Space Approach to  
Modulation



Analog and Digital Communications





# Overview

- We have described three families of modulation schemes known as Phase Shift Keying, Frequency Shift Keying, and Amplitude Shift Keying
  - Each of these can be binary or  $M$ -ary
  - We have also looked at combinations of these (QAM)
- We would like to examine the performance of all of the modulation schemes discussed
- To do so, we need a method of representing any modulation scheme known as the *signal space method*
- The signal space concept will allow us to design the optimal receiver and determine its performance

# Key Ideas from I/Q Representation of Signals



Analog and Digital Communications

$$s(t) = x(t) \cos(2\pi f_c t) - y(t) \sin(2\pi f_c t)$$

- We can represent bandpass signals independent of carrier frequency.
- The idea of quadrature sets up a coordinate system for looking at common modulation types.
- The coordinate system is sometimes called a signal constellation diagram.
- In-phase (Real part of complex baseband) maps to x-axis and Quadrature (imaginary part of complex baseband) maps to the y-axis

# Example of Signal Constellation Diagram: QPSK



Analog and Digital Communications

$$s_i(t) = A \cos(2\pi f_c t + \theta_i)$$

$$\theta_i = \begin{cases} \frac{\pi}{4} & b_i b_{i+1} = 00 \\ \frac{3\pi}{4} & b_i b_{i+1} = 10 \\ -\frac{3\pi}{4} & b_i b_{i+1} = 11 \\ -\frac{\pi}{4} & b_i b_{i+1} = 01 \end{cases}$$

$$s_i(t) = x_i(t) \cos(2\pi f_c t) - y_i(t) \sin(2\pi f_c t)$$

$$x_i(t) = \begin{cases} \frac{A\sqrt{2}}{2} & b_i = 0 \\ -\frac{A\sqrt{2}}{2} & b_i = 1 \end{cases} \quad y_i(t) = \begin{cases} \frac{A\sqrt{2}}{2} & b_{i+1} = 0 \\ -\frac{A\sqrt{2}}{2} & b_{i+1} = 1 \end{cases}$$

# Example of Signal Constellation Diagram: QPSK



Analog and Digital Communications

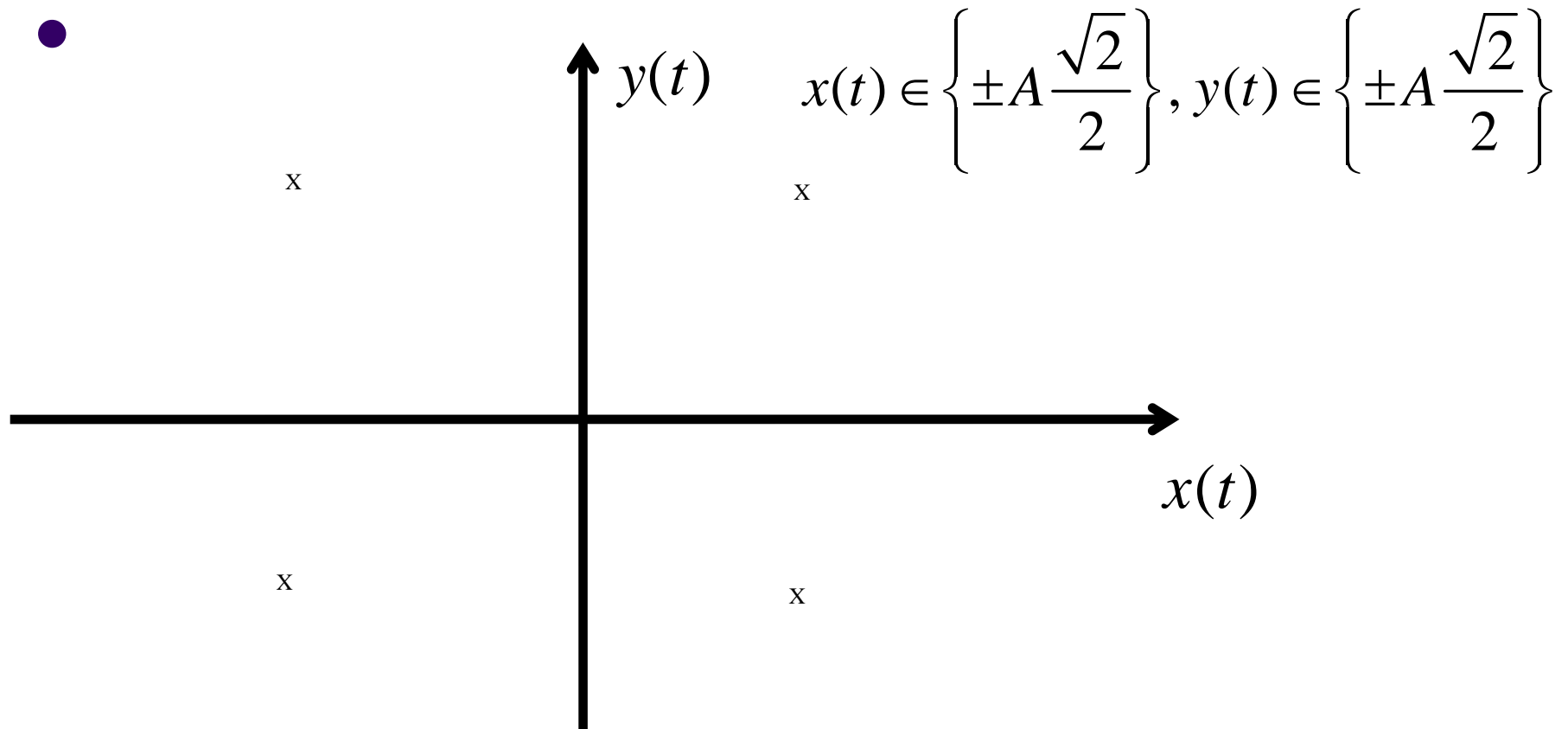

# Interpretation of Signal Constellation Diagram



Analog and Digital Communications

- Axis are labeled with  $x(t)$  and  $y(t)$ 
  - In-phase/quadrature or real/imaginary
- Possible symbols are plotted as points
- Symbol amplitude is proportional to distance from origin
- Probability of mistaking one signal for another is related to the distance between signal points
- Decisions are made on the received signal based on the distance of the received signal (in the I/Q plane) to the signal points in the constellation

# A New Way of Viewing Modulation



Analog and Digital Communications

- The I/Q representation of modulation is very convenient for some modulation types.
- We will examine an even more general way of looking at modulation using signal spaces.
- By choosing an appropriate set of axes for our signal constellation, we will be able to:
  - Design modulation types which have desirable properties
  - Construct optimal receivers for a given modulation
  - Analyze the performance of modulation types using very general techniques.

# Basis Functions for a Signal Set



- For any modulation scheme one of  $M$  signals (often termed symbols) is transmitted during each symbol interval

$$\{s_1(t), \dots, s_M(t)\}$$

- We would like to create a set of  $K \leq M$  signals that can be used to build any symbol in my set
  - If  $K \ll M$  this will be more efficient than having to generate  $M$  different signals
- Specifically, we say that the functions  $\{f_1(t), \dots, f_K(t)\}$  ( $K \leq M$ ) form a *complete orthonormal basis* for the signal set if

- Any signal can be described by a linear combination:

$$s_i(t) = \sum_{k=1}^K s_{i,k} f_k(t), i = 1, \dots, M$$

- The basis functions are orthogonal to each other:

$$\int_a^b f_i(t) f_j^*(t) dt = 0, \forall i \neq j$$

- The basis functions are normalized:

$$\int_a^b |f_k(t)|^2 dt = 1, \forall k$$

Note: The time interval  $[a,b]$  is the symbol time

# Signal Spaces



Analog and Digital Communications

- The resulting set of basis functions can be thought of as a *signal space* by creating a space where the dimensions represent the basis functions
- For each symbol the coefficients for the set of basis functions can be represented as a vector
- The resulting vector represents a point in our signal space
- Ex:  $s_1(t) = a*f_1(t) + b*f_2(t) \rightarrow [a, b]$

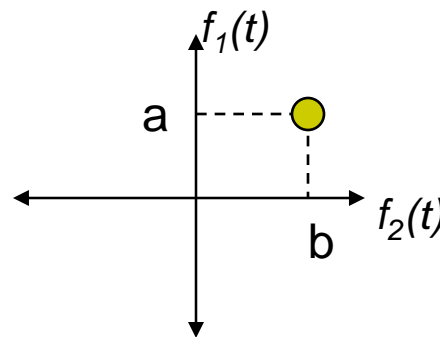

# Example of Signal Space



Analog and Digital Communications

Consider the following signal set:

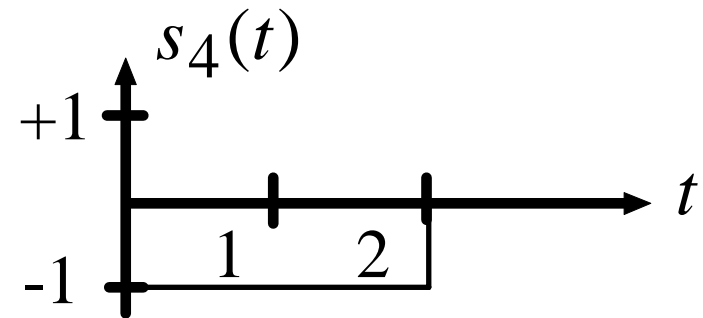
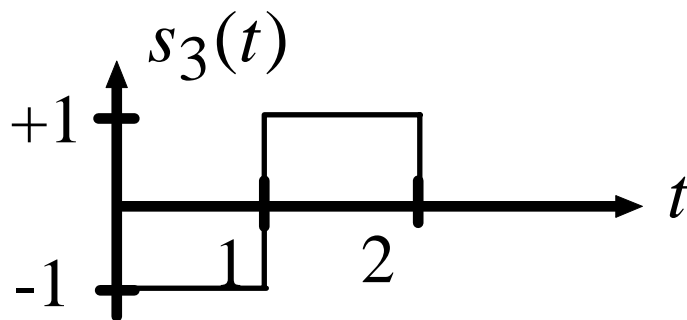
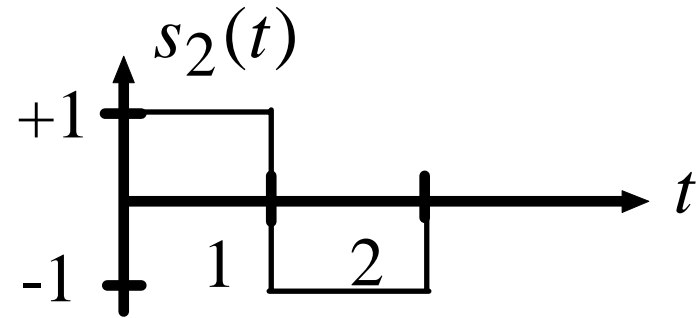
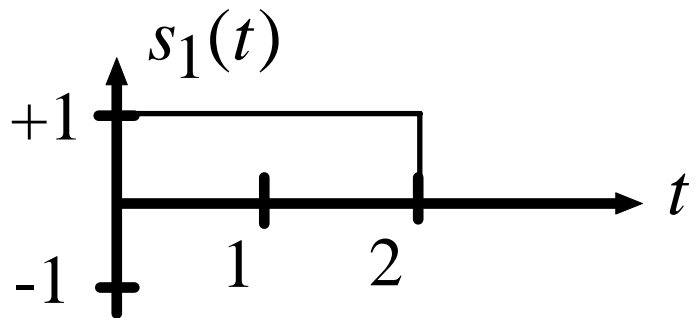

# Example of Signal Space (continued)



Analog and Digital Communications

- We can express each of the signals in terms of the following basis functions:

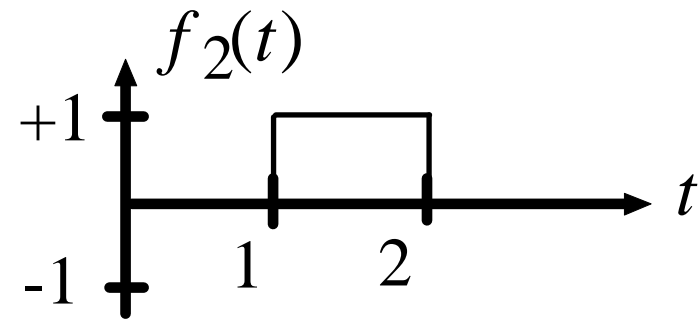
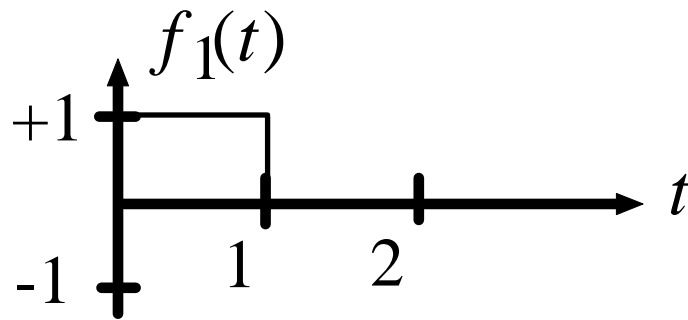

$$s_1(t) = 1 \cdot f_1(t) + 1 \cdot f_2(t)$$

$$s_2(t) = 1 \cdot f_1(t) - 1 \cdot f_2(t)$$

$$s_3(t) = -1 \cdot f_1(t) + 1 \cdot f_2(t)$$

$$s_4(t) = -1 \cdot f_1(t) - 1 \cdot f_2(t)$$

- Therefore the basis is complete

# Example of Signal Space (continued)



Analog and Digital Communications

- The basis is orthogonal:

$$\int_{-\infty}^{\infty} f_1(t) f_2^*(t) dt = 0$$

- The basis is normalized:

$$\int_{-\infty}^{\infty} |f_1(t)|^2 dt = \int_{-\infty}^{\infty} |f_2(t)|^2 dt = 1$$

# Signal Space Diagram



Analog and Digital Communications

- Axes represent the basis functions. Points are placed at the coefficients

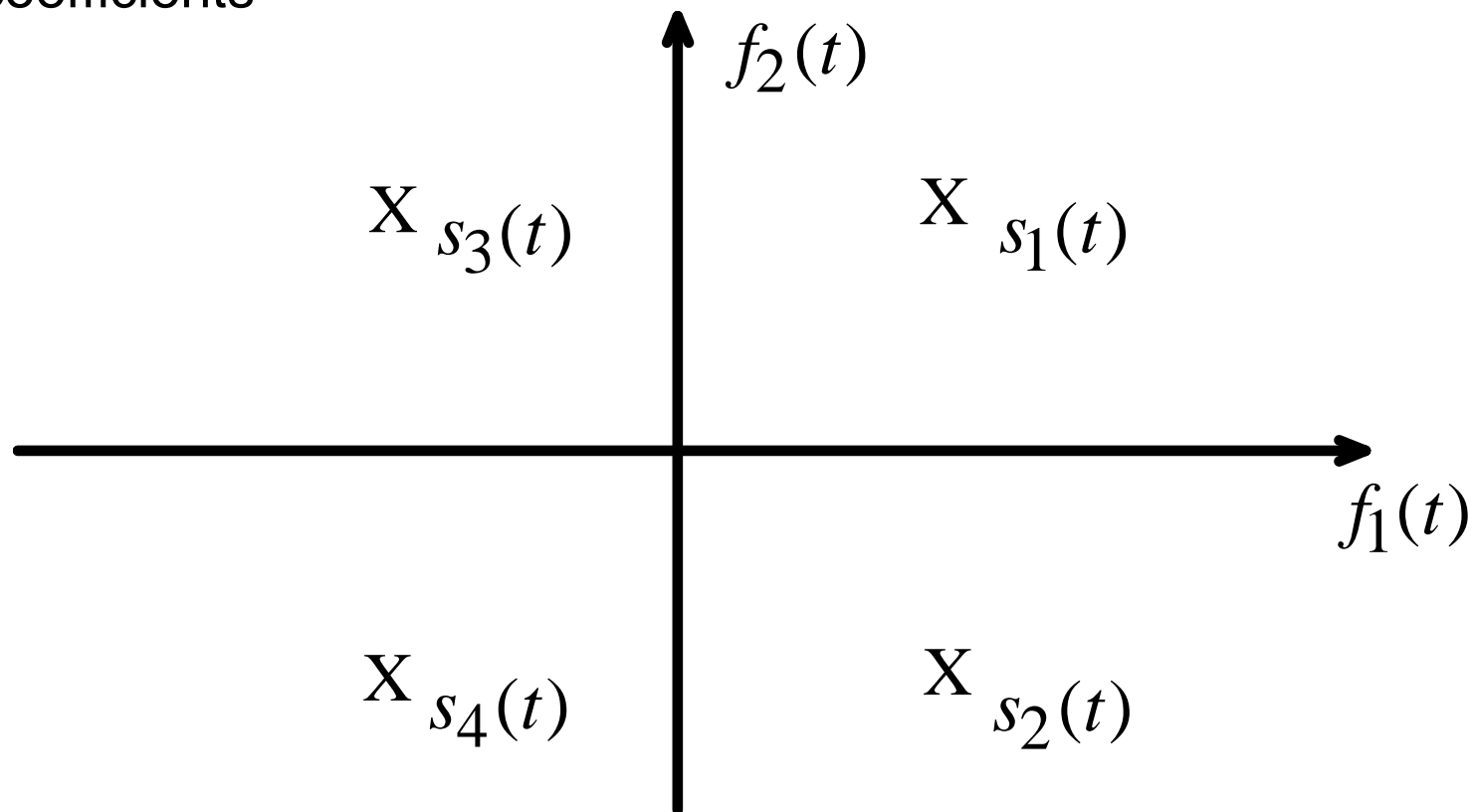

# Another Example



- Suppose our signal set can be represented in I/Q form:

$$s(t) = x(t) \cos(2\pi f_c t) - y(t) \sin(2\pi f_c t) \Big|_0^T$$

where  $x(t)$  and  $y(t)$  are constants for  $t \in [0, T]$

- Then the functions:

$$f_1(t) = \sqrt{\frac{2}{T}} \cos(2\pi f_c t) \Big|_0^T, f_2(t) = \sqrt{\frac{2}{T}} \sin(2\pi f_c t) \Big|_0^T$$

form a complete orthonormal basis

# Proof



- All I/Q signals can be represented by the linear combination of these basis functions.
- These basis functions are orthogonal:

$$\begin{aligned}\int_0^T f_1(t) f_2^*(t) dt &= \int_0^T \sqrt{\frac{2}{T}} \cos(2\pi f_c t) \cdot \sqrt{\frac{2}{T}} \sin(2\pi f_c t) dt \\ &= \frac{2}{T} \int_0^T \frac{1}{2} [\sin(0) + \sin(4\pi f_c t)] dt \\ &= \frac{-1}{4\pi f_c T} [\cos(4\pi f_c t)]_0^T \approx 0, \text{ for } f_c T \gg 1\end{aligned}$$

# Proof (continued)



- These basis functions are normalized:

$$\begin{aligned} \int_0^T |f_1(t)|^2 dt &= \int_0^T |f_2(t)|^2 dt = \int_0^T \left( \sqrt{\frac{2}{T}} \cos(2\pi f_c t) \right)^2 dt \\ &= \frac{2}{T} \int_0^T \frac{1}{2} [\cos(0) + \cos(4\pi f_c t)] dt \approx \frac{1}{T} [1]_0^T = 1 \end{aligned}$$



# Constellation Diagrams

- Thus, constellation diagrams are simply signal space plots for modulation schemes that have only two basis functions.
- Specifically, basis functions are  $\sqrt{2/T} \cos(2\pi ft)$  and  $\sqrt{2/T} \sin(2\pi ft)$  over the symbol duration  $[0, T)$
- Only good for phase modulation or amplitude modulation
- Other modulation formats require larger number of basis functions.



# Energy Per Symbol

$$\begin{aligned} E_i &= \int_0^T |s_i(t)|^2 dt \\ &= \int_0^T \left| \sum_k v_k f_k(t) \right|^2 dt \\ &= \int_0^T \left( \sum_m \sum_k v_k v_m f_k(t) f_m^*(t) \right) dt \\ &= \sum_m \sum_k v_k v_m \left[ \int_0^T f_k(t) f_m^*(t) dt \right] \\ &= \sum_k v_k^2 \end{aligned}$$

For BER comparison purposes we would like to plot signals in terms of *Energy per Symbol*

# Notes on Signal Spaces



Analog and Digital Communications

- Two entirely different signal sets can have the same geometric representation.
- The underlying geometry will determine the performance and the receiver structure for a signal set.
- In both of these cases we were fortunate enough to guess the correct basis functions.
- Is there a general method to find a complete orthonormal basis for an arbitrary signal set?
  - **Yes: *The Gram-Schmidt Procedure***
- Note that FSK will require  $M$  basis functions

# Signal Space: $M$ -PSK



- The symbols of  $M$ -PSK can be written as

$$s_i(t) = \cos\left(2\pi f_c t + \frac{2\pi}{M} i\right) \Big|_0^T, \quad i = 0, \dots, M-1$$

- The two basis functions are

$$f_1(t) = \sqrt{\frac{2}{T}} \cos(2\pi f_c t) \Big|_0^T \quad f_2(t) = -\sqrt{\frac{2}{T}} \sin(2\pi f_c t) \Big|_0^T$$

$$s_i(t) = c_{1i} f_1(t) + c_{2i} f_2(t) = c_{1i} \sqrt{\frac{2}{T}} \cos(2\pi f_c t) - c_{2i} \sqrt{\frac{2}{T}} \sin(2\pi f_c t)$$

$$c_{1i} = \sqrt{\frac{T}{2}} \cos\left(\frac{2\pi}{M} i\right) \quad c_{2i} = \sqrt{\frac{T}{2}} \sin\left(\frac{2\pi}{M} i\right)$$



# Average Symbol Energy

- All symbols have equal energy

$$\begin{aligned} E_s &= \frac{T}{2} \cos^2 \left( \frac{2\pi}{M} i \right) + \frac{T}{2} \sin^2 \left( \frac{2\pi}{M} i \right) \\ &= \frac{T}{2} \end{aligned}$$

- Writing the symbols in terms of the energy per symbol:

$$\mathbf{s}_i = \left[ \sqrt{E_s} \cos \left( \frac{2\pi}{M} i \right) \quad \sqrt{E_s} \sin \left( \frac{2\pi}{M} i \right) \right]$$

# Ex: 8-ary PSK

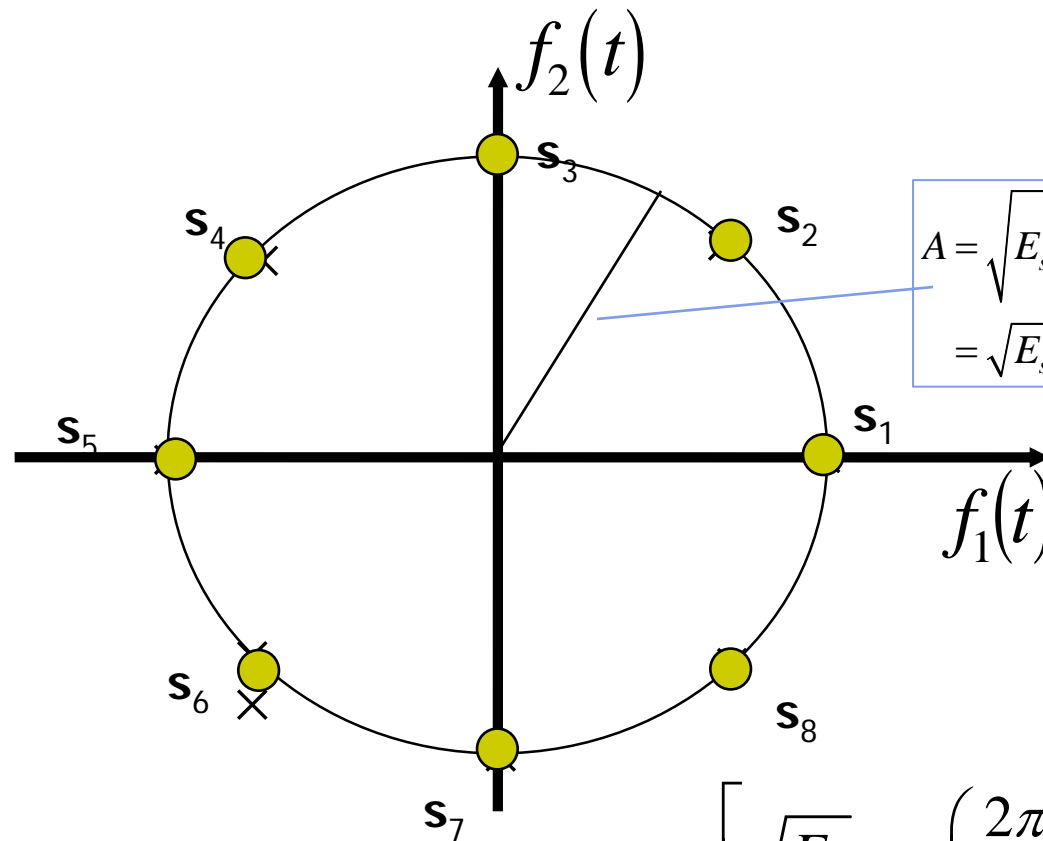

$$A = \sqrt{E_s \cos^2\left(\frac{2\pi}{M}i\right) + E_s \sin^2\left(\frac{2\pi}{M}i\right)}$$
$$= \sqrt{E_s}$$

$$\mathbf{s}_i = \left[ \sqrt{E_s} \cos\left(\frac{2\pi}{M}i\right) \quad \sqrt{E_s} \sin\left(\frac{2\pi}{M}i\right) \right]$$



# Distance Between Symbols

- The distance between symbols has a direct impact on the BER performance

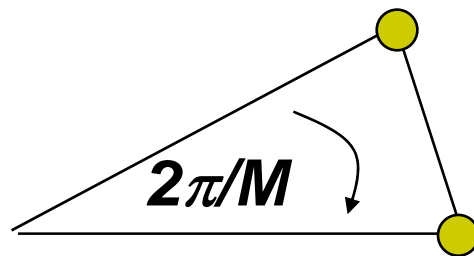

$$\begin{aligned}d &= \sqrt{A^2 + A^2 - 2A^2 \cos(2\pi / M)} \\&= \sqrt{2A^2 (1 - \cos(2\pi / M))} \\&= \sqrt{4A^2 \sin^2(\pi / M)}\end{aligned}$$

- Substituting for the average energy per symbol:

$$d = \sqrt{4E_s \sin^2(\pi / M)}$$

Distance decreases dramatically as  $M$  increases

- Changing to energy per bit:

$$d = \sqrt{4E_b \log_2(M) \sin^2(\pi / 2M)}$$



# Signal Space: *M*-FSK

- Consider the signal set

$$s_i(t) = \sqrt{\frac{2}{T}} \cos(2\pi f_c t + 2\pi i \Delta f t)$$

- With baseband equivalent

$$s_i(t) = \sqrt{\frac{2}{T}} e^{j2\pi i \Delta f t}$$

- We can show that the correlation between symbols is

$$\begin{aligned} \rho_{mn} &= \frac{1}{T} \int_0^T e^{j2\pi(m-n)\Delta f t} dt \\ &= \frac{\sin[\pi T(m-n)\Delta f]}{\pi T(m-n)\Delta f} e^{j\pi T(m-n)\Delta f} \end{aligned}$$



# M- FSK (cont.)

- If we choose  $\Delta f = 1/T$ , the correlation between symbols is zero thus we will need  $M$  basis functions (i.e., one for each symbol).

$$f_i(t) = \sqrt{\frac{2}{T}} \cos\left(2\pi f_c t + \frac{2\pi i}{T} t\right)$$

- Further, we can represent the symbols in signal space as  $M$ -dimensional vectors:

$$\overline{E}_s = 1$$

$$\mathbf{s}_1 = \begin{bmatrix} \sqrt{E} & 0 & 0 & 0 & \dots & 0 \end{bmatrix}$$

$$\mathbf{s}_2 = \begin{bmatrix} 0 & \sqrt{E} & 0 & 0 & \dots & 0 \end{bmatrix}$$

$$\mathbf{s}_3 = \begin{bmatrix} 0 & 0 & \sqrt{E} & 0 & \dots & 0 \end{bmatrix}$$

$$\vdots$$

$$\mathbf{s}_M = \begin{bmatrix} 0 & 0 & 0 & 0 & \dots & \sqrt{E} \end{bmatrix}$$

# Ex: BFSK



Analog and Digital Communications

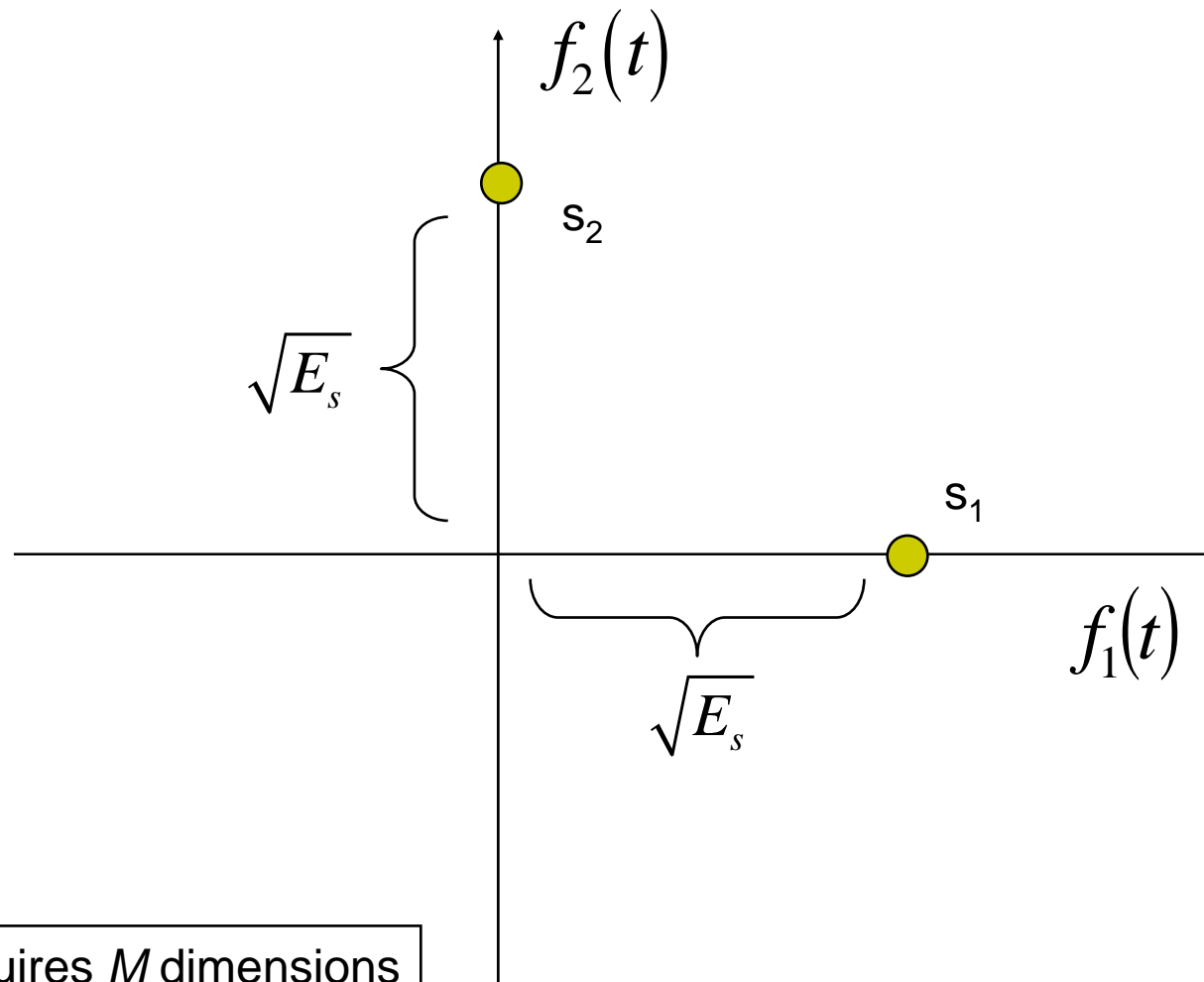

$M$ -ary FSK requires  $M$  dimensions



# Distance Between Symbols

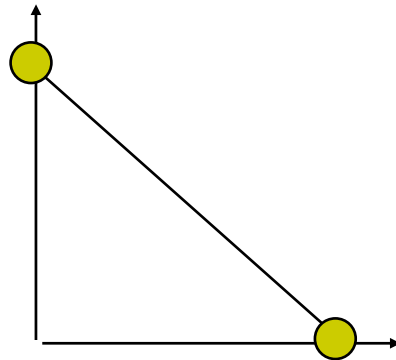

$$d = \sqrt{2E_s}$$

- As we increase  $M$  the number dimensions increases and thus the distance between points does not decrease
- In fact, in terms of energy per bit:

$$d = \sqrt{2E_b \log_2(M)}$$

Distance actually increases as  $M$  increases (in terms of energy per bit).<sup>27</sup>

# Signal Space: $M$ -ASK



- The symbols of  $M$ -ASK can be written as

$$s_i(t) = i \cos(2\pi f_c t) \Big|_0^T, \quad i = 0, \dots, M-1$$

- There is one basis function:

$$f_1(t) = \sqrt{\frac{2}{T}} \cos(2\pi f_c t) \Big|_0^T$$

$$s_i(t) = c_i f_1(t) = c_i \cos(2\pi f_c t)$$

$$c_i = \sqrt{\frac{T}{2}} i$$



# Average Symbol Energy

- All symbols have *different* energies

$$E_s = \int_0^T \left\{ \sqrt{\frac{T}{2}} i \sqrt{\frac{2}{T}} \cos(\omega_c t) \right\}^2 dt$$
$$= i^2 \frac{T}{2}$$

- Average Energy:

$$\overline{E_s} = \frac{1}{M} \sum_{i=0}^{M-1} \left( \sqrt{\frac{T}{2}} i \right)^2 = \frac{1}{M} \frac{T}{2} \sum_{i=0}^{M-1} i^2$$



# Example: 4-ASK

- Symbols

$$s_0(t) = 0 \Big|_0^T$$

$$s_1(t) = \cos(\omega_c t) \Big|_0^T$$

$$s_2(t) = 2 \cos(\omega_c t) \Big|_0^T$$

$$s_3(t) = 3 \cos(\omega_c t) \Big|_0^T$$

- Basis function

$$f_1(t) = \sqrt{\frac{2}{T}} \cos(2\pi f_c t) \Big|_0^T$$

- Coefficients

$$c_0 = 0 \quad c_1 = \sqrt{\frac{T}{2}}$$

$$c_2 = 2\sqrt{\frac{T}{2}} \quad c_3 = 3\sqrt{\frac{T}{2}}$$



## Example (cont.)

- Average Energy

$$\begin{aligned}\overline{E}_s &= \frac{1}{M} \sum_{i=0}^3 \left( \sqrt{\frac{T}{2}} i \right)^2 = \frac{T}{2} \frac{1}{4} \{0 + 1 + 4 + 9\} \\ &= \frac{7T}{4}\end{aligned}$$

$$c_0 = 0 \quad c_1 = \sqrt{\frac{2}{7} \overline{E}_s}$$

$$c_2 = \sqrt{\frac{8}{7} \overline{E}_s} \quad c_3 = \sqrt{\frac{18}{7} \overline{E}_s}$$

# Ex: 4-ASK



Analog and Digital Communications

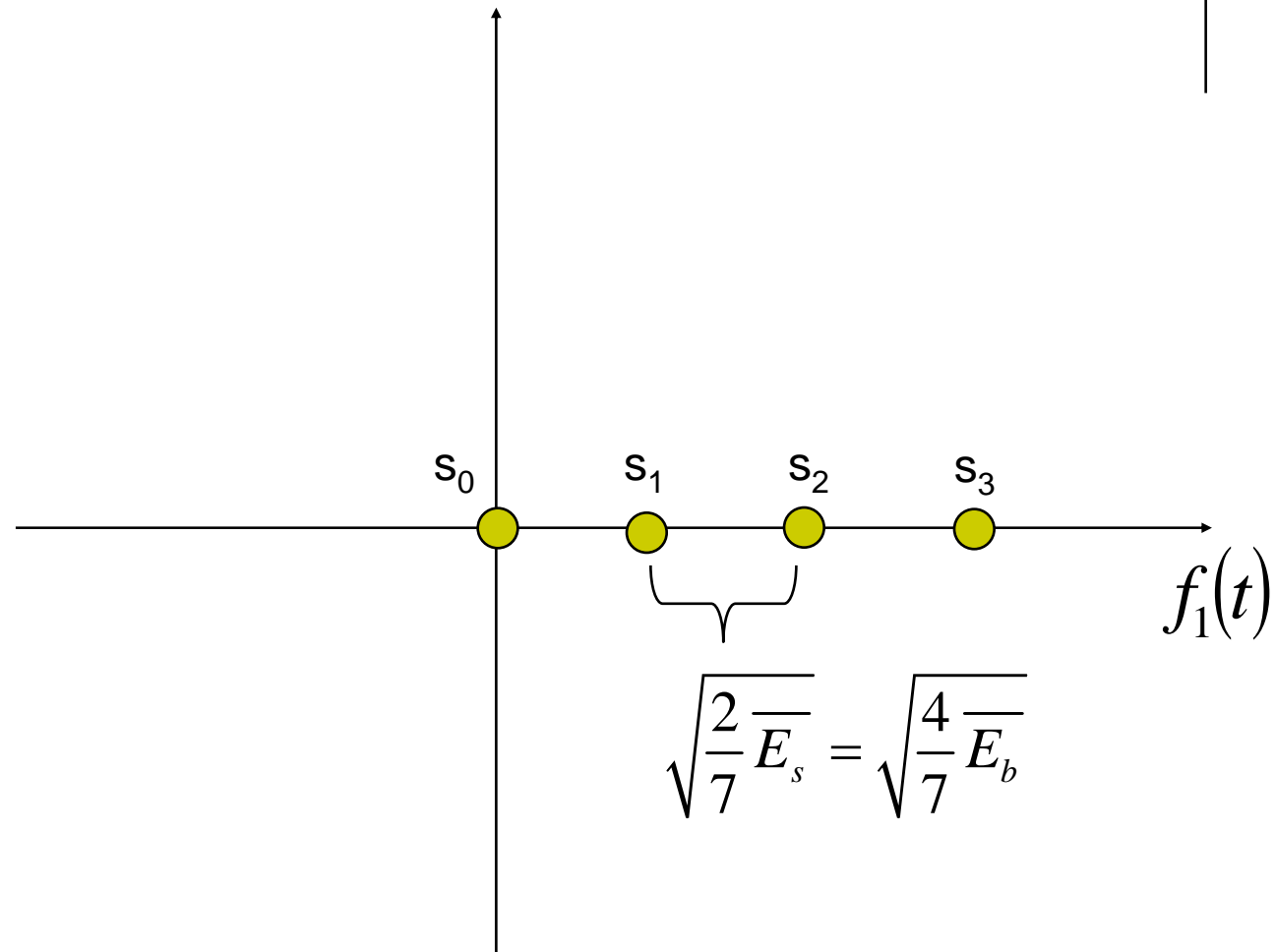

# Signal Space: 16-QAM



Analog and Digital Communications

- The symbols of QAM can be written as

$$s_i(t) = x(t)\cos(\omega_c t) - y(t)\sin(\omega_c t)\Big|_0^T$$

$$x(t) \in \{-3, -1, 1, 3\}, y(t) \in \{-3, -1, 1, 3\}$$

- The two basis functions are

$$f_1(t) = \sqrt{\frac{2}{T}} \cos(2\pi f_c t)\Big|_0^T \quad f_2(t) = -\sqrt{\frac{2}{T}} \sin(2\pi f_c t)\Big|_0^T$$

$$s_i(t) = c_{1i} f_1(t) + c_{2i} f_2(t)$$

$$= c_{1i} \cos(2\pi f_c t) - c_{2i} \sin(2\pi f_c t)$$

$$\begin{array}{l} c_{1i} \in \left\{ -3\sqrt{\frac{T}{2}}, -\sqrt{\frac{T}{2}}, \sqrt{\frac{T}{2}}, 3\sqrt{\frac{T}{2}} \right\} \\ c_{2i} \in \left\{ -3\sqrt{\frac{T}{2}}, -\sqrt{\frac{T}{2}}, \sqrt{\frac{T}{2}}, 3\sqrt{\frac{T}{2}} \right\} \end{array}$$

# Example : 16-QAM

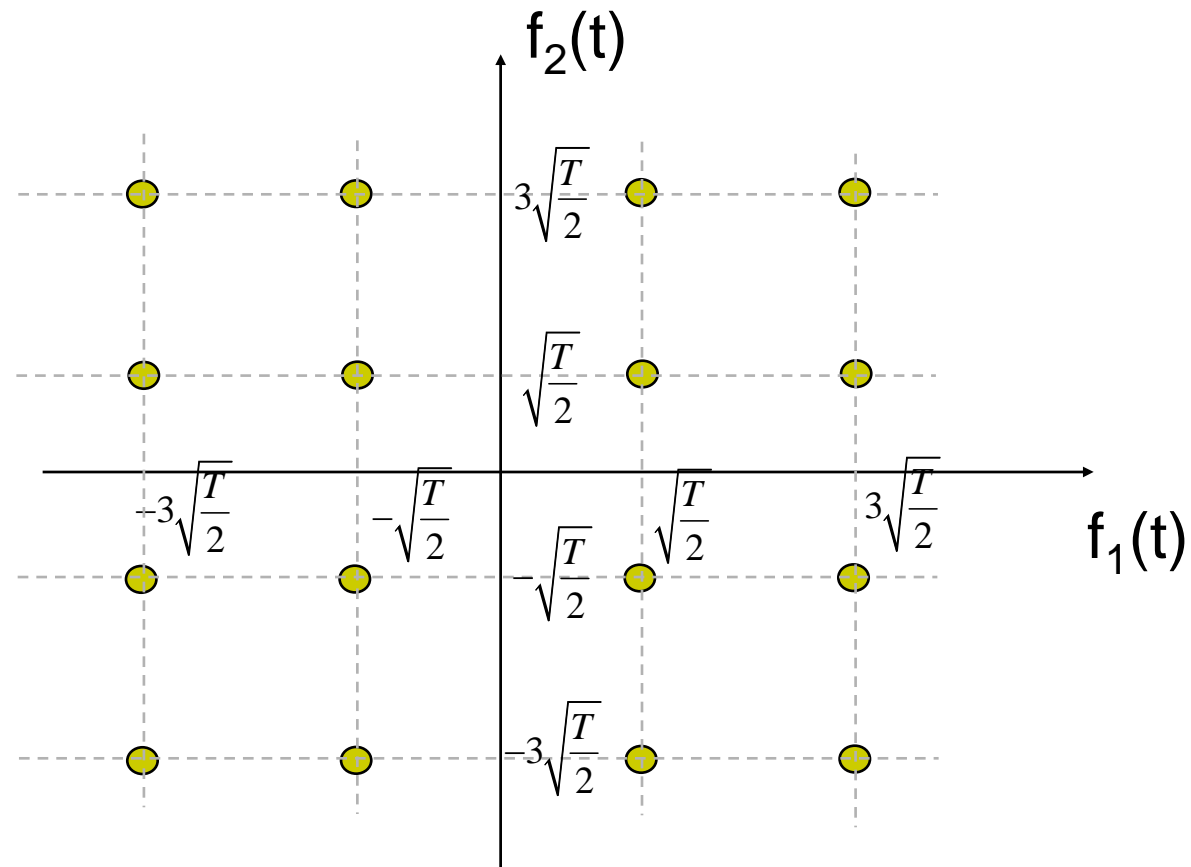



# Average Symbol Energy

- Symbol energies

$$E_s = T \quad \text{Four symbols}$$

$$E_s = 10 \frac{T}{2} = 5T \quad \text{Eight symbols}$$

$$E_s = 18 \frac{T}{2} = 9T \quad \text{Four Symbols}$$

- Thus, the average symbol energy

$$\begin{aligned} \overline{E_s} &= \frac{1}{16} \{4 * T + 8 * 5T + 4 * 9T\} \\ &= 5T \end{aligned}$$

# Example : 16-QAM

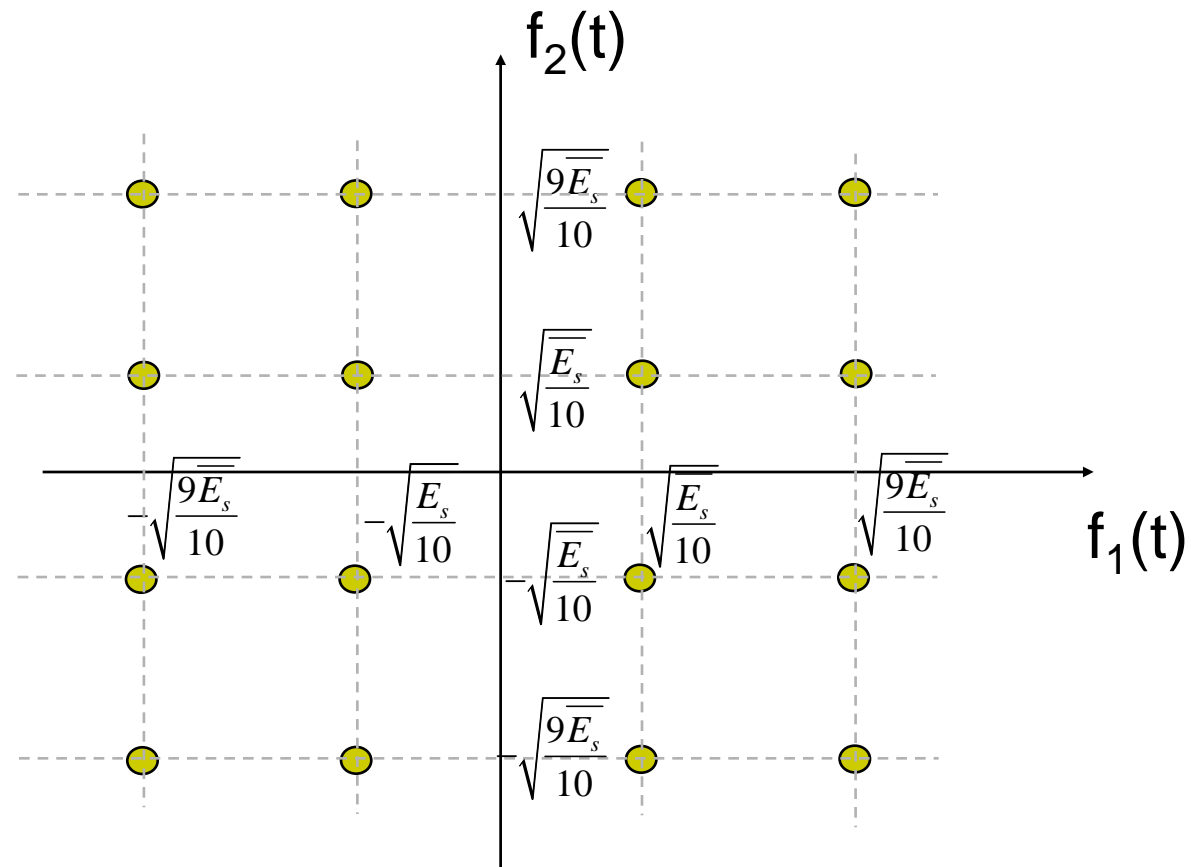



# Pulse Shaping

- Q: How is pulse shaping handled with the signal space approach?
- A: By incorporating the pulse shape into the basis function.
  - This was implicitly done previously
  - Example: MPSK

$$f_1(t) = \sqrt{\frac{2}{T}} \cos(2\pi f_c t) \Big|_0^T \quad f_2(t) = -\sqrt{\frac{2}{T}} \sin(2\pi f_c t) \Big|_0^T$$

- Can be written as

$$f_1(t) = \sqrt{\frac{2}{T}} \cos(2\pi f_c t) \Pi\left(\frac{t-T/2}{T}\right)$$

$$f_2(t) = -\sqrt{\frac{2}{T}} \sin(2\pi f_c t) \Pi\left(\frac{t-T/2}{T}\right) \quad 37$$



# Pulse Shaping (cont.)

- For arbitrary pulse shaping with M-PSK

$$f_1(t) = \sqrt{\frac{2}{T}} \cos(2\pi f_c t) p(t) \quad f_2(t) = -\sqrt{\frac{2}{T}} \sin(2\pi f_c t) p(t)$$

- Where  $p(t)$  is an arbitrary pulse shape with unit energy
- The constellation diagrams would not change
  - Thus, distance properties wouldn't change and assuming matched filtering, the performance wouldn't change

# Generic Transmitter (MPSK, MASK, QAM)



Analog and Digital Communications

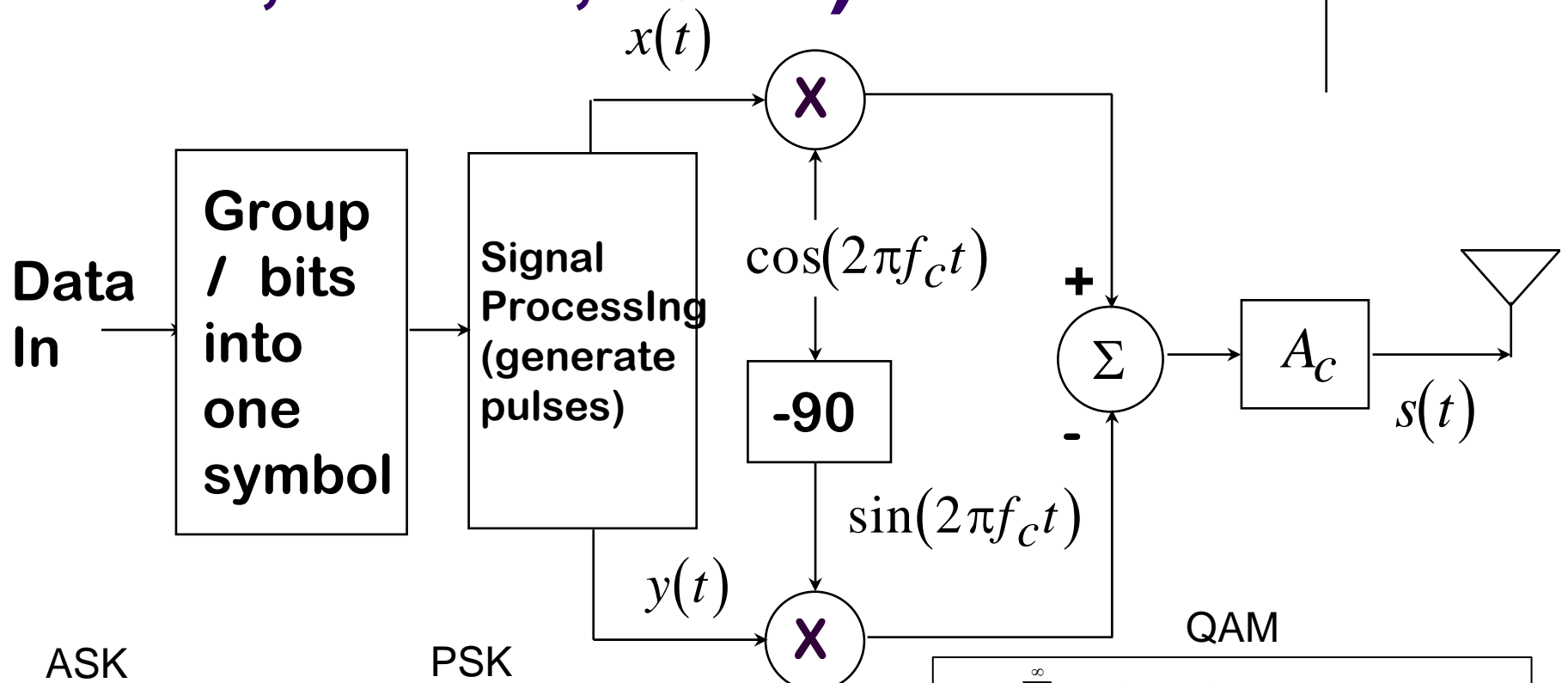

ASK

$$x(t) = \sum_{n=-\infty}^{\infty} A_n p(t - nT_s)$$

$$A_n = A_1, A_2, \dots, A_M$$

$$y(t) = 0$$

PSK

$$x(t) = \sum_{n=-\infty}^{\infty} A_n p(t - nT_s)$$

$$A_n = \cos(\theta_1), \cos(\theta_2), \dots, \cos(\theta_M)$$

$$y(t) = \sum_{n=-\infty}^{\infty} B_n p(t - nT_s)$$

$$B_n = \sin(\theta_1), \sin(\theta_2), \dots, \sin(\theta_M)$$

QAM

$$x(t) = \sum_{n=-\infty}^{\infty} A_n p(t - nT_s)$$

$$A_n = \frac{1}{\sqrt{E_{avg}}} \{-\sqrt{M} + 1, -\sqrt{M} + 3, \dots, \sqrt{M} - 3, \sqrt{M} - 1\}$$

$$y(t) = \sum_{n=-\infty}^{\infty} B_n p(t - nT_s)$$

$$B_n = \frac{1}{\sqrt{E_{avg}}} \{-\sqrt{M} + 1, -\sqrt{M} + 3, \dots, \sqrt{M} - 3, \sqrt{M} - 1\}$$



# Summary

- We have presented the signal space representation for all of the major digital modulation schemes
  - Distance between symbols reduces for MPSK, MASK
  - Distance between symbols increases (in terms of  $E_b/N_o$ ) for MFSK
- Pulse shaping can be easily incorporated into this framework
- Approach leads to straightforward transmitter (and as we will see next time) receiver implementation