

ECE4634 Digital Communications Fall 2007

Instructor: R. Michael Buehrer
Lecture #8: Digital Pulse Modulation
Non-Uniform Quantization,
DPCM,
Delta Modulation



1

Overview



- In a digital communications system, analog signals must be converted to digital waveforms.
- The most common version of this is known as PCM and involves
 - Sampling
 - Quantizing
 - Mapping bits to waveforms
- We have looked at sampling and *uniform quantization*.
 - Today we will look at more sophisticated quantization techniques.

RM Buehrer
Virginia Tech
Fall 2007

2

Lecture Objectives



- The objective of today's lecture is to show that when the statistics of the analog signal are known, more efficient (as compared to PCM with uniform quantizing) analog-to-digital conversion techniques are possible including
 - Non-uniform quantization through companding
 - Delta modulation (DM)
 - Differential PCM
 - Model-based Encoding
- We will also examine the performance of companding and DM

RM Buehrer
Virginia Tech
Fall 2007

3

Non-Uniform Quantization



- A quantizer for which $\tilde{x}_{k-1} - \tilde{x}_k = \Delta, \forall k \in \{1, \dots, L-1\}$ is called a uniform quantizer.
- It is sometimes better to use non-uniform spacing
- Examine the distortion measure: $D = \int_{-\infty}^{\infty} (x - \tilde{x})^2 f(x) dx$
- We wish to make $(x - \tilde{x})^2$ small when $f(x)$ is large.
- We can accept larger $(x - \tilde{x})^2$ when $f(x)$ is small.
- **Basic principle:** concentrate quantization levels in area of largest pdf.
- One way of accomplishing this is *companding*.

RM Buehrer
Virginia Tech
Fall 2007

4

Companding



- Nonuniform quantizers can give better performance for most signals than uniform quantizers when the input signal is not uniformly distributed
- One way of accomplishing this is to distort the incoming signal and perform uniform quantization
- Companding introduces a nonlinearity into the signal
 - This maps a nonuniform distribution into something that more closely resembles a uniform distribution
 - A standard ADC with uniform spacing between levels can be used after the compander
 - The companding operation is inverted after reception

Compressor/Expander = Compander

RM Buehrer
Virginia Tech
Fall 2007

5

Communications System with Companding

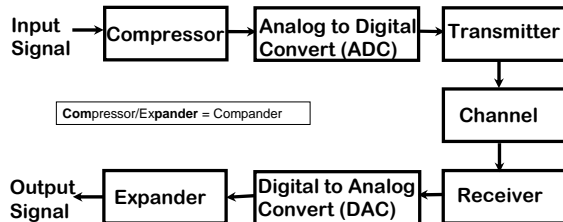

RM Buehrer
Virginia Tech
Fall 2007

6

Common Nonlinearities used by Companders



- Mu-Law (used in North America and Japan)

$$|v(t)| = \frac{\ln(1 + \mu |m(t)|)}{\ln(1 + \mu)}, \text{ usually } \mu = 255$$

Note that $v(t)$ and $m(t)$ are normalized to unity maximum value

- A-Law (used in Europe)

$$|v(t)| = \begin{cases} \frac{A |m(t)|}{1 + \ln A}, & 0 \leq |m(t)| \leq \frac{1}{A} \\ \frac{1 + \ln(A |m(t)|)}{1 + \ln A}, & \frac{1}{A} \leq |m(t)| \leq 1 \end{cases}$$

usually $A = 87.6$

RM Buehrer
Virginia Tech
Fall 2007

7

Characteristics of μ -law Compressor



- Compressor circuit *compresses* the higher values in order to emphasize the lower values.
- The slope of the characteristic can be determined as

$$\begin{aligned} \frac{d|v(t)|}{d|m(t)|} &= \frac{d}{d|m(t)|} \left[\frac{\ln(1 + \mu |m(t)|)}{\ln(1 + \mu)} \right] \\ &= \frac{1}{\ln(1 + \mu)} \frac{d}{d|m(t)|} [\ln(1 + \mu |m(t)|)] \\ &= \frac{1}{\ln(1 + \mu)} \frac{1}{1 + \mu |m(t)|} \mu \\ &= \frac{\mu}{\ln(1 + \mu)} \frac{1}{1 + \mu |m(t)|} \end{aligned}$$

RM Buehrer
Virginia Tech
Fall 2007

8

μ -law (cont.)



$$\frac{d|v(t)|}{d|m(t)|} = \frac{\mu}{\ln(1 + \mu)} \frac{1}{1 + \mu |m(t)|}$$

- For small values of $m(t)$ ($\mu |m(t)| \ll 1$)

$$\frac{d|v(t)|}{d|m(t)|} \approx \frac{\mu}{\ln(1 + \mu)}$$

- Characteristic is linear

- For large values of $m(t)$ ($\mu |m(t)| \gg 1$)

$$\frac{d|v(t)|}{d|m(t)|} \approx \frac{\mu}{\ln(1 + \mu)} \frac{1}{\mu |m(t)|} = \frac{1}{\ln(1 + \mu)} \frac{1}{|m(t)|}$$

- Slope decreases with increasing $m(t)$ [compression]

RM Buehrer
Virginia Tech
Fall 2007

9

Uniform Quantization



- If we set $\mu=0$:

$$|v(t)| = \frac{\ln(1+0)}{\ln(1+0)} = \frac{0}{0}$$

- Using L'Hopital's rule

$$|v(t)| = \left[\frac{\frac{d}{d\mu} [\ln(1+\mu|m(t)|)]}{\frac{d}{d\mu} [\ln(1+\mu)]} \right]_{\mu=0}$$

$$= \left[\frac{\frac{1}{1+\mu|m(t)|} |m(t)|}{\frac{1}{1+\mu}} \right]_{\mu=0}$$

$$= |m(t)|$$

Thus, $\mu=0$ corresponds to no compression and thus uniform quantization

Input/Output Relationship for Compandor

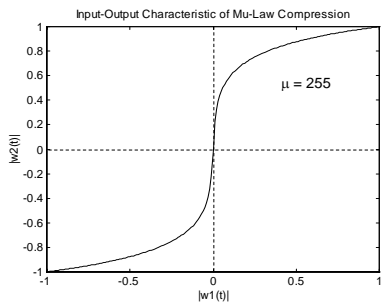

RM Buehner
Virginia Tech
Fall 2007

11

PDF of Signal Processed by Compressor ($\mu = 255$)

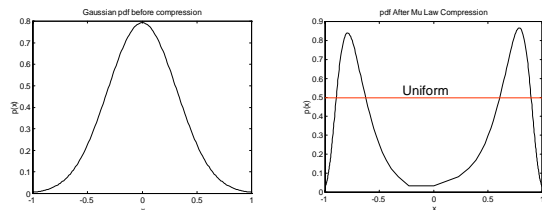

For Gaussian distributed signal it is not perfect, but the pdf flattens out some

RM Buehner
Virginia Tech
Fall 2007

12

PDF of Voice Signal Processed by Compressor ($\mu = 255$)

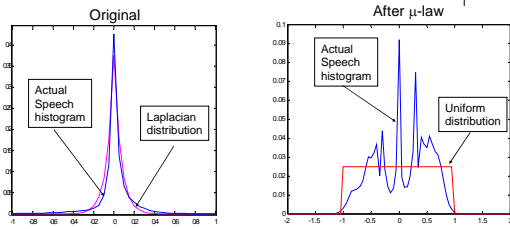

Again, it is not perfect, but the pdf is a much closer approximation to uniform

RM Buehrer
Virginia Tech
Fall 2007

13

Performance of Companding



- It can be shown that for *non-uniformly distributed* signals, using a uniform quantizer (no companding), the output signal to noise ratio is

$$\left(\frac{S}{N}\right)_{dB} = 6.02n + \left(4.77 - 20\log\left(\frac{V}{x_{rms}}\right)\right) \text{ dB}$$

A typical value for V/x_{rms} is 10 meaning that

$$\left(\frac{S}{N}\right)_{dB} = 6.02n - 15.2 \text{ dB}$$

- By contrast, the SNR for μ -law companding is

$$\left(\frac{S}{N}\right)_{dB} = 6.02n + (4.77 - 20\log(\ln(1 + \mu))) \text{ dB}$$

Unlike uniform quantizer, μ -law companding has SNR that is approximately independent of peak-to-average voltage V/x_{rms}

RM Buehrer
Virginia Tech
Fall 2007

14

Performance of Companding

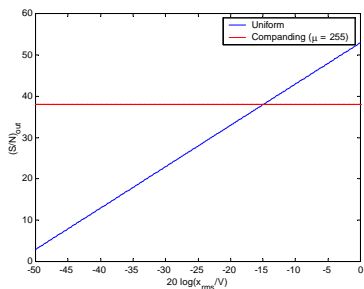

At large values of peak-to-average power (small values of average-to-peak) companding provides large benefits.

RM Buehrer
Virginia Tech
Fall 2007

15

Practical Implementation of μ -Law Companding

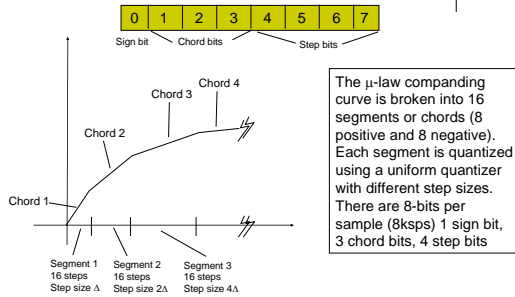

RM Buehrer
Virginia Tech
Fall 2007

19

64 kbit/sec PCM for U.S. Telephone Lines:



- Uses companding with $\mu=255$.
- Samples 4 kHz speech waveform at 8,000 sample/sec.
- Encodes each sample with 8 bits, $M=256$ quantizer.
- Data rate = 64 kbit/sec
- Used in US phone systems.
- However, 64kbps \rightarrow 32kHz minimum bandwidth using optimal pulse shaping (much greater than the original 4kHz analog signal)
- Thus, in wireless systems where spectrum is premium, speech coding techniques must be used

RM Buehrer
Virginia Tech
Fall 2007

20

Measurement of Distortion for Speech



- There exist several alternative distortion measures besides MSE
- MSE may not give best indication of quality speech
- No single quantitative measure has been found which accurately quantifies perceptual quality.
- Subjective Assessment of Speech Quality involves Mean Opinion Score (MOS) Testing:
 - Subjects rate speech on a scale of 1 (unintelligible) to 5 (perfect).
 - Toll quality telephone speech rates around 4.3.

RM Buehrer
Virginia Tech
Fall 2007

21

Coding Techniques for Speech



All speech coding techniques employ quantization. PCM does not exploit the properties of speech. It is possible to reduce bit rates by exploiting the properties of speech:

- Temporal Waveform Coding - attempt to represent time domain samples of speech waveform by exploiting temporal correlation.
- Spectral Waveform Coding - attempt to exploit spectral characteristics of speech waveform.
- Model-Based Encoding - attempt to replicate a model of the process by which speech was constructed.

RM Buehrer
Virginia Tech
Fall 2007

22

Temporal Waveform Coding Techniques - Delta Modulation



- In delta modulation, the signal is heavily oversampled to introduce correlation between consecutive samples.
- Due to the heavy correlation, we use 1 bit per sample where the bit represents $\pm \Delta$ as compared to the previous value.
- Delta modulation can be implemented with an extremely simple 1 bit quantizer.
- Trade-off exists between step size and sampling rate. The higher the sampling rate the lower the step size needed to avoid overload noise (and the lower the granular noise) but the higher the required data rate.

RM Buehrer
Virginia Tech
Fall 2007

23

Delta Modulation

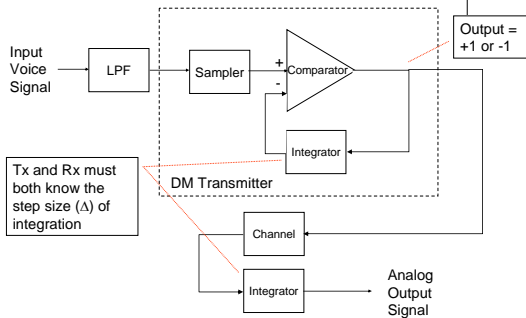

RM Buehrer
Virginia Tech
Fall 2007

24

Delta Modulation

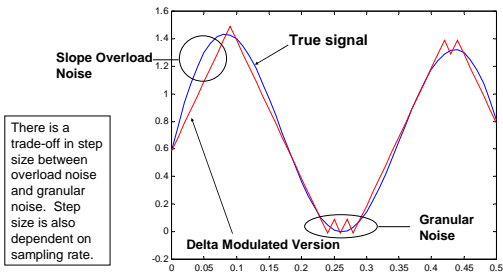

RM Buehrer
Virginia Tech
Fall 2007

25

Avoiding Overload Noise



- Overload noise can be eliminated if the step size Δ is chosen to be larger than (or equal to) the maximum change between samples
- In other words we want $\Delta \geq T_s \max \left| \frac{dm(t)}{dt} \right|$ where T_s is the sampling period ($1/f_s$) and $m(t)$ is the message signal of interest.
- We can relate this to the signal bandwidth as

$$\begin{aligned} \Delta &\geq T_s \max \left| \frac{d}{dt} \int_{-B}^B M(f) e^{j2\pi f t} df \right| \\ &= T_s \max \left| \int_{-B}^B (j2\pi f) M(f) e^{j2\pi f t} df \right| \leq T_s \max \left| \int_{-B}^B (j2\pi B \operatorname{sgn}(f)) M(f) e^{j2\pi f t} df \right| \\ &= T_s 2\pi B V_p \end{aligned}$$

RM Buehrer
Virginia Tech
Fall 2007

26

Granular Noise



- If granular noise is uniformly distributed between the maximum positive error (Δ) and the maximum negative value error ($-\Delta$), the total granular noise power is

$$\begin{aligned} N_{gr} &= \int_{-\Delta}^{\Delta} x^2 f_x(x) dx \\ &= \frac{1}{2\Delta} \int_{-\Delta}^{\Delta} x^2 dx \\ &= \frac{1}{2\Delta} \left[\frac{x^3}{3} \right]_{-\Delta}^{\Delta} \\ &= \frac{\Delta^2}{3} \end{aligned}$$

RM Buehrer
Virginia Tech
Fall 2007

27

SNR



- The signal-to-noise ratio of the Delta Modulation Signal if slope overload is avoided is thus

$$\begin{aligned}
 SNR &= \frac{P_{sig}}{N_{sig}} \\
 &= \frac{3P_{avg}}{\Delta^2} \\
 &= \frac{3P_{avg}}{(T_s 2\pi B V_p)^2} \\
 &= \frac{3f_s^2}{4\pi^2 B^2} \left(\frac{P_{avg}}{V_p^2} \right)
 \end{aligned}$$

RM Buehrer
Virginia Tech
Fall 2007

$\left(\frac{V_p^2}{P_{avg}} \right)$ is typically referred to as the peak-to-average power ratio

Granular Noise (cont.)



- However, since the signal is highly oversampled, this noise power is spread over a range of frequencies that is larger than the original signal bandwidth
- Additionally the noise power is found to have a uniform power spectral density.
- Thus we can reduce the granular noise power by filtering.
- The actual noise power experienced is

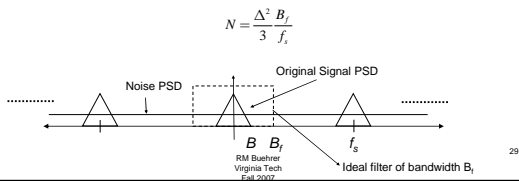

SNR revisited



- If we filter the signal to a bandwidth of B_f the SNR is

$$SNR = \frac{3f_s^2}{4\pi^2 B^2} \left(\frac{P_{avg}}{V_p^2} \right) \frac{f_s}{B_f} = \frac{3f_s^3}{4\pi^2 B^2 B_f} \left(\frac{P_{avg}}{V_p^2} \right)$$

- For a sinusoid, $P_{avg} = V_p^2 / 2$:

$$SNR = \frac{3f_s^3}{8\pi^2 f_o^2 B^2 B_f}$$

Voice Signals



- For voice signals, it turns out that the frequencies around 800Hz dominate the perception of slope overload
- Thus, for voice signals we desire $\Delta \geq \frac{2\pi 800V_p}{f_s}$
- Using a filter bandwidth equal to the voice signal bandwidth $B_f = B$, the resulting SNR is then

$$\begin{aligned} \left(\frac{S}{N}\right)_{out} &\approx \frac{P_{avg}}{N} = \frac{P_{avg} f_s}{N_{tot} B} \\ &= \frac{3P_{avg} f_s}{\Delta^2 B} \\ &= \frac{3f_s^3}{(1600\pi)^2 B} \frac{P_{avg}}{V_p^2} \end{aligned}$$

RM Buehrer
Virginia Tech
Fall 2007

31

SNR Comparison - Voice

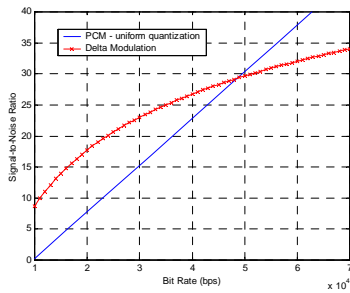

$B = 4\text{kHz}$
Peak-to-Average
Power Ratio = 4

Delta Modulation yields better performance than PCM for low data rates but worse performance at high data rates

RM Buehrer
Virginia Tech
Fall 2007

32

Temporal Waveform Coding Techniques - Differential PCM



- Speech is very strongly correlated from one instant to the next.
- DPCM quantizes the difference between one sample and the predicted value of the next sample. (This is usually much less than the absolute value of the samples).

RM Buehrer
Virginia Tech
Fall 2007

33

Differential PCM



- Given several past samples of a speech signal it is possible to predict the next sample to a high degree of accuracy by using a **linear prediction filter**.
- The error of the prediction filter is much smaller than the actual signal itself.
- In **differential pulse-code modulation (DPCM)**, the error at the output of a prediction filter is quantized, rather than the voice signal itself.
- DPCM can produce “toll-quality” speech at half the normal bit rate (i.e. 32 kbps).

DPCM Block Diagram

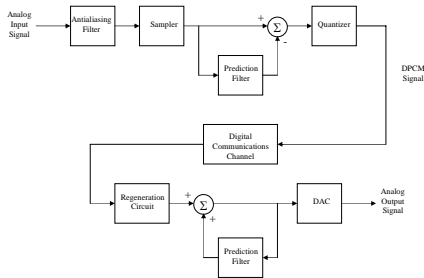

DPCM Issues



- The linear prediction filter is usually just a feedforward (FIR) filter.
- The filter coefficients must be periodically transmitted.
- In **adaptive differential pulse-code modulation (ADPCM)**, the quantization resolution can be changed on the fly.
- **Delta modulation** is a special case of DPCM where there are only two quantization levels.
- While DPCM works well on speech, it does not work well for modem signals.

Model-Based Techniques



- Linear Predictive Speech Coders (LPC)
- Speech is divided into frames of approximately 20 ms.
- Human speech is modeled as noise (air from the lungs) exciting a linear filter (throat, vocal cords, and mouth).
- The excitation sequence and filter coefficients are quantized by an LPC speech encoder
- These vocoders are employed in most cellular standards

RM Buehrer
Virginia Tech
Fall 2007

37

Block Diagram of LPC Model of Speech

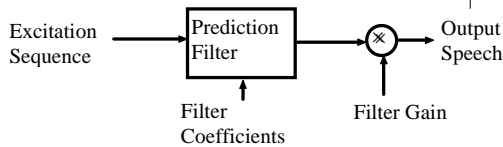

- LPC quantizes Excitation Sequence, Filter Coefficients and Filter Gain and transmits those to receiver.
- Vector Quantization is frequently used on these values

RM Buehrer
Virginia Tech
Fall 2007

38

Vector Sum Excited Linear Prediction (VSELP)



- Employed in U.S. Digital Cellular (IS-136) standard.
- 20 ms frames. Each frame is represented with 159 bits. Total data rate is approximately 8 kbits/sec.
- A two stage vector quantizer is used to quantize the excitation sequence.
- Some bits (like filter gain) are much more important for perpetual quality than others. These are protected by error correction coding.
- CDMA cellular systems use 13kbps Qualcomm Code Excited Linear Prediction (Q-CELP) or 8kbps EVRC
- GSM systems use 13.2kbps Residual Pulse Excited – Long Term Prediction (RPE-LTP)

RM Buehrer
Virginia Tech
Fall 2007

39

Example 8.3 – LPC Samples



Original Voice sound (PCM 64kbps)



LPC encoded Voice sound (2400bps)



2400bps LPC example

Note that we haven't yet considered bit errors!

RM Buehrer
Virginia Tech
Fall 2007

40

Example 8.4: Voice Coding



PCM encoded (μ -law) 64kbps



ADPCM encoded 32kbps



GSM Vocoder (13.2kbps)



LPC (4.8kbps)



LPC (1.4kbps)

RM Buehrer
Virginia Tech
Fall 2007

41

Comparison of Speech Coding Standards



Type	Rate (kb/s)	Complexity (MIPS)	Delay (ms)	MOS	Quality
PCM	64	0.01	0	4.4	high
ADPCM	32	0.1	0	4.2	high
Sub-band	16	1	25		high
VSELP	8	~100	35	3.6	fair
Other LPC	1.4				poor
Theory	~1	?	?	?	high

RM Buehrer
Virginia Tech
Fall 2007

42

Summary



- PCM with standard sampling and quantization is the simplest way to convert analog signals (e.g., voice) into bits. These bits are then mapped to waveforms.
- PCM requires approximately 64kbps to achieve good performance with voice signals
- However, there are more sophisticated ways to convert analog speech to bits that reduces the number of bits (and thus data rate) required
 - ADPCM
 - Delta modulation
 - Vocoders
- The lower the bit rate required, the lower the bandwidth that will be needed as we will see next time.

RM Buehrer
Virginia Tech
Fall 2007

43
