

The Defense Advanced Research Projects Agency (DARPA)
Networking in Extreme Environments (NETEX) Program

TEST MASTER PLAN FOR THE NETEX PROGRAM

1.0 INTRODUCTION

This document provides a plan for testing a number of selected military systems to determine the susceptibility of the receivers to electromagnetic interference (EMI) from the very narrow pulses (and pulse trains) of transmitters associated with Ultra-Wideband (UWB) systems. The selected military systems provide a representative sample of communications, navigation and radar systems that are currently used in military applications. All of the selected systems have previously been tested for susceptibility to EMI in accordance with the procedures of MIL-STD-462/462D/461E and to the susceptibility levels specified in the version of MIL-STD-461 current at the time the candidate system was originally procured. (The current version of MIL-STD-461 is MIL-STD-461E. With the approval of MIL-STD-461E, the test procedures previously contained in MIL-STD-462D were incorporated into MIL-STD-461E.)

1.1 Overview of Tests

The primary emphasis of this test plan will be directed toward performing conducted susceptibility tests at the antenna port of selected military receivers. The reason for concentrating the effort on conducted tests instead of radiated tests is to better control the tests conditions experienced by the equipment under test (EUT). Although the conducted tests will form the bulk of the test procedures, radiated tests will also be performed to demonstrate the effects resulting from radiated coupling of single and multiple UWB emitters on a receiver. MIL-STD-461E test procedures will be used as a guide for performing the tests.

1.2 Overview of Test Plan

The susceptibility tests will be performed on approximately 20 selected receivers used by the U.S. military. Since each type of military receiver selected for testing possesses different equipment characteristics, only general test plans are provided in the main body of this document. Thus, this test master plan provides guidance for determining the test parameters but does not contain detailed information on the test requirements for individual receivers. The test master plan will be used as a guide to determine the test requirements based on the operational characteristics for each selected military receiver. Prior to performing tests, a specific test plan will be developed for each receiver and these specific test plans will be published as appendices to this master plan.

2.0 BACKGROUND

Recent advances in microcircuits and other technologies have resulted in the development of pulsed radar and communications systems with very narrow pulse widths and very wide bandwidths. The U.S. Federal Communications Commission (FCC) has defined a UWB device to be any intentional radiator of radio frequency (RF) energy, which has a 10 dB bandwidth of 25% of the strongest frequency within that 10 dB bandwidth or a 10 dB bandwidth of equal to or greater to 500 MHz. Because of these extremely large bandwidths, these devices do not conform to the U.S. frequency allocation table and the associated Federal Regulations.

UWB devices can perform a number of useful telecommunication functions that make them very appealing for both the commercial and government applications. These systems have very wide information bandwidths, are capable of accurately locating nearby objects, and can use processing technology with UWB pulses to “see through objects” and communicate using multiple propagation paths.

Typically the output power of UWBs is low enough to be authorized under the unlicensed device regulations of the National Telecommunications and Information Administration (NTIA) and the FCC. However, these bandwidths are so wide that, UWB devices usually also emit signals in bands that are used for other allocated RF services. Emissions are not permitted in the previously allocated bands because of the potential harmful effects to the users of these bands.

The NTIA and the FCC developed rules for unlicensed devices (conventional electronic devices with narrow bandwidths and very low total radiated power, usually less than 1 W) that did not address the then unknown UWB devices. Thus, NTIA and the FCC must work closely with each other and the users they authorize as well as with the UWB community to develop policies and procedures that will allow the UWB devices to work without interference to existing systems. The difficulty in measuring both the UWB signal characteristics and their effects on other devices exacerbates the difficulties of this coordination. The pulses are very narrow, often in the low nanosecond or picosecond range, requiring new measurement techniques and equipment to measure the signal characteristics accurately. Further, the interference effects of very narrow pulses with high repetition rates and aggregations of similar devices, such as could occur in some applications of UWB technology, are not well understood.

2.1 Overview of NETEX Program

The Defense Advanced Research Projects Agency (DARPA) is the central research and development organization for the Department of Defense (DoD). It manages and directs basic and applied research and development projects for DoD, pursuing technology where risk and payoff are usually both very high. High payoff results may provide dramatic advances in communication support to our ability to wage modern warfare. The DARPA Networking in Extreme Environments (NETEX) program seeks to create a wireless networking technology for the military user that enables robust connectivity in a

wide spectrum of environments and support its integration into new and emerging sensor and communication systems.

The NETEX program will develop an improved physical layer for networked communications based on a family of new UWB devices. These devices will enable reliable and efficient operations in harsh environments by exploiting the unique properties of UWB systems that allow them to work in a dense multi-path environment and to function as both sensors and communications devices. The program will adapt new and emerging ad-hoc routing protocols and multiple access schemes to take advantage of the unique properties of UWB to communicate in harsh environments, to very accurately resolve range, and to act as a radar based sensor.

The NETEX program will explore the EMI effects of UWB on co-located systems and the benefits of combining the attributes inherent in a UWB network to form a distributed communications and sensor system. The UWB system will enable reliable communications to operators, sensors, and robots in harsh and urban terrain not possible with existing RF devices and systems. Additionally, the system will enable a collection of distributed cooperative sensor network applications such as radar tomography.

2.2 NTIA UWB EMI Investigation

The NTIA has previously conducted an assessment of the EMC between UWB emitters and selected federal systems. The NTIA investigation included a series of measurements and analyses for characterizing and assessing the impact of UWB devices on selected federal systems operating between 400 MHz and 6,000 MHz. The results of the NTIA assessment included the development of practical methods for characterizing UWB devices and provided the information needed to estimate or measure the potential for UWB devices to interfere with existing radio communications or sensing systems. This test plan, which is directed toward assessing the susceptibility of selected military systems to UWB signals, leverages and builds upon the approach to UWB EMI analyses and measurements conducted by the NTIA.

3.0 TEST OBJECTIVES

The objective of this effort is to investigate the susceptibility of selected military communication, navigation, and radar receivers to EMI from UWB devices. The results of this investigation will provide the information necessary to evaluate the potential for UWB devices to interfere with existing military radio communication and sensing systems and help to understand how UWB systems could be implemented in a manner that makes optimum use of their unique capabilities.

4.0 APPROACH

4.1 Test Facilities and Personnel

The work described in this Test Plan will be conducted at the Electromagnetic

Environmental Effects (E3) Division of the Naval Air Warfare Center Aircraft Division (NAWCAD), Patuxent River, Maryland. This is a unique facility with highly qualified personnel resources. The test will be performed by E3 personnel that are experts in EMI testing. The Patuxent River facility provides an excellent opportunity to obtain measurements that characterize the effects on military RF equipment of radiated UWB waveforms from any such source under highly controlled conditions.

Of major importance is the experience of the personnel at the E3 Division of NAWCAD with similar testing of military RF equipment and systems. This experience should maximize utilization of resources and provide a thorough characterization of UWB interference on representative military systems. The testing process must produce results to support analyses that are easily used to determine the effects of UWB signals on existing systems and on spectrum efficiency, in general. The tests will seek to develop further understanding of the interference effects of individual UWB signals on a variety of military equipment, and the characteristics of interference of an aggregate of UWB signals on this same equipment.

4.2 UWB Waveform Generators

The NETEX Program Office will obtain a set of twenty-five (25) identical UWB signal generators that will be able to emulate a range of UWB characteristics to support the requirements of this test master plan. These devices are being developed and supplied by Multispectral Solutions, Inc. (MSSI) and will be able to produce all of the UWB waveforms, frequencies, and power levels necessary for these tests and be able to operate synchronously or asynchronously as required. Generally, the devices will have a fixed baseband pulse (which is nominally 250 ps long), variable baseband pulse (which is nominally 0.5 ns to 10.0 ns long) and short pulse RF from 20 MHz to 24 GHz, achieved through the use of “narrow” passband filtering of the baseband pulses. The UWB Signal Generators will provide a wide range of possible UWB signal shapes, bandwidths, pulse repetition rates and power levels to facilitate UWB interference testing and evaluation (T&E). Through an arbitrary waveform generator (ARB) in the UWB controller, the UWB will be able to generate an extensive variation of waveforms including, but not limited to, regular pulse repetition rates (PRR) up to 100 million pulses per second (Mpps), randomly jittered PRR up to $\pm 100\%$ jitter, swept jitter, planned pulse position modulation (PPM), and random PPM.

The UWB Signal Generator will provide both baseband (0 – 26 GHz) and filtered baseband pulses that are representative of the pulses used for UWB applications. The operating frequency bands for the filtered baseband pulses are tentatively set at: 20 MHz to 88 MHz, 100 MHz to 200 MHz, 200 MHz to 400 MHz, 950 MHz to 1,250 MHz, 1,100 MHz to 1,600 MHz, 4,200 MHz to 4,400 MHz, and 13,200 MHz to 13,400 MHz. The specific characteristics for the baseband pulses are still in the process of being defined.

In addition to the UWB generators, the program will obtain a set of reference antennas for the piecewise continuous sub-bands of the UWB generated signal. A set of non-reference antennas will also be obtained and calibrated against the reference antennas.

Prior to actual testing, a number of preparatory steps will be taken. The first will be to design and develop whatever control software is required to drive the individual parameters of all the UWB devices. Custom software may also be required to collect and store the measurements made on the selected military systems.

4.3 Basis for Tests - MIL-STD-461E and MIL-STD-464

The test procedures and techniques described in MIL-STD-461E *Department of Defense Interface Standard, Requirements for the Control of Electromagnetic Interference Characteristics of Systems and Equipment*, and MIL-STD-464 *Department of Defense Interface Standard, Electromagnetic Environmental Effects Requirements for Systems* will be used as the basis for the tests. Both conducted and radiated tests will be performed. The most applicable test procedure for conducted tests is MIL-STD-461E Method CS-104, Conducted Susceptibility Antenna Port, Rejection of Undesired Signals 30Hz to 20GHz. For radiated tests, MIL-STD-464 will be used as the basis for development of the test plan.

It is important to note that there are several significant differences between the requirements and objectives of these tests and the classical MIL-STD-461E tests. First, MIL-STD-461E applies to EMI from out-of-band emissions, whereas, the interfering signal from a UWB emitter will probably have spectral components that are in the receiver passband. Second, the objective of MIL-STD-461E is to verify that the receiver can operate in the presence of an interfering signal that is at the applicable limits whereas the objective of this test plan is to determine the potential susceptibility threshold for the selected equipments.

4.4 Test Equipment Calibration

All test equipment used for measurement purposes during UWB EMI testing shall be calibrated by a calibration laboratory using methods and standards traceable to the National Institute of Standards and Technology (NIST). All test reports shall include a listing of all measurement equipment used with a listing of the last calibration date and the date the next calibration is due. No measurement equipment will be used which is due for recalibration during the anticipated period of an individual equipment's testing.

5.0 EQUIPMENTS TO BE TESTED

The victim receivers used in the testing will be both individual devices (e.g., frequency modulated (FM) Radio), and, where possible, complete complex systems (e.g. F/A-18, or mobile communications, command, and control [C³] shelters such as AN/TSQ-131). The primary airborne receivers to be tested are the ones installed on the F/A-18. The RF equipments used on the F/A-18 provide a representative sample of equipments that are used by U.S. military aircraft. Table 1 lists many of the equipments on the F/A-18 and provides the allocated operating frequency bands and smallest intermediate frequency (IF) filter bandwidths for these equipments. *It is obvious that there is a lot of data*

NETEX Test Master Plan
Draft 8/15/02

missing from Table 1. There are two reasons for missing data. First, some of the equipments on the F/A-18 are classified and this data was not included in Table 1 so the test plan could remain unclassified. Second, some of the data was not available through normal sources and, will be collected as the test plan continues to evolve. In addition to the receivers resident on an F/A-18 listed in Table 1, other military receiver candidates for interference testing are provided in Table 2. Final selection of candidate receivers will be based on applicability to the testing process and availability of the receivers and the necessary support test equipment. Every equipment selected will be verified against its own specifications to insure that it is operating properly and to establish its range of normal operation.

TABLE 1 F/A-18 RF Systems

NOMENCLATURE	FREQUENCY BAND (MHz)	IF BANDWIDTH (MHz)	SENSITIVITY (dBm)	REFERENCE J/F 12/
COMMUNICATIONS EQUIPMENT				
AN/ARC-210 (also has SINCGARS mode, shown in Fig. 2 below)	30-88 118-156 156-174 225-400	0.030 0.035 0.0801	FM -108 AM -103 FM -108 AM -103; FM -108	07149 06635/2
AN/ASQ-T16 TACTS	1830 or 1840	1.2	-99	04324/2
NAVIGATION EQUIPMENT				
AN/APN-194(V) (Altimeter)	4200-4400	30	-83	05501
AN/APN-202 (Radar Beacon)	8800-9500			03544
AN/ARN-118 (TACAN)	962-1213	0.400	-89	04116/4
OA-86970/ARD (ADF)				
AN/ASN-172(V)4 (GPS)	1227.60 1575.42	20	-137	07277
AN/ASN-163 (GPS)	1227.60 1575.42	20	-137	07277
AN/ARA-63A (ILS)	LOC. 108- 117.95	0.040	-103.5	06348
	GS. 329.15- 335	0.070	-87	
	75	0.030	-55	
R-1623/APN	30000-33400	18	-35	05552
RT-1379A/ASW (DATA)	300 – 325	0.0345	-103.2	05603
MIDS/TACAN	Classified	Classified		

NETEX Test Master Plan
Draft 8/15/02

NOMENCLATURE	FREQUENCY BAND (MHz)	IF BANDWIDTH (MHz)	SENSITIVITY (dBm)	REFERENCE J/F 12/
IFF EQUIPMENT				
AN/APX-72	1030			01990/2
AN/APX-100	1030	5.5	-77	07090
AN/APX-111(V)	1030	9.8	-77	06996
	1090	7.6	-84	06995
FCS RADAR EQUIPMENT				
AN/APG-65	Classified	Classified	Classified	
AN-APG-73	Classified	Classified	Classified	
EW EQUIPMENT				
AN/ALQ-126B (CM)	Classified	Classified	Classified	
AN/ALQ-165(V) (CM)	Classified	Classified	Classified	
AN/ALQ-214 (CM)	Classified	Classified	Classified	
AN/ALR-67(V)2	Classified	Classified	Classified	
SPECIAL EQUIPMENT				
AN/URT-33A	243.00			
AN/AWW-13	Classified	Classified	Classified	

TABLE 2 Additional Candidate Military RF Systems

NOMENCLATURE	FREQUENCY BAND (MHz)	IF BANDWIDTH (MHz)	SENSITIVITY (dBm)	REFERENCE J/F 12/
COMMUNICATIONS EQUIPMENT				
SINCGARS	30 – 87.975	0.015	-118	04967/6
	30 – 87.975	0.032	-116	05764/6
	108 – 151.975	0.032	-110.4	
	136 – 173.975	0.032	-118	
EPLRS RT-1344/TSQ-129 RT-1572/TSQ-158 RT-1573/G	425.75 - 446.75	3	-103	04547/2
AN/TRC-170	4400 – 4999.9	Variable: 2 or 4	-110	04480/4
AN/MRC-142	1350-1850	0.800	-93	06461
Lamps D/L	15,245 or 15,315	1	-103	07377
AN/USC-59 LMST	3625 – 4200	40	-119	07347
	7250 – 7750	40	-112	
	10,950 – 12,750	40	-109	

*NETEX Test Master Plan
Draft 8/15/02*

NOMENCLATURE	FREQUENCY BAND (MHz)	IF BANDWIDTH (MHz)	SENSITIVITY (dBm)	REFERENCE J/F 12/
SHF SATCOM	7250-7750			
EHF SATCOM	20,295 – 20,595	24	-91.21 Ship -92.9 Shore	07741
TACTICAL COLLISION AVOIDANCE SYSTEM (TCAS)				
TCAS	1030	12	-80	07091 07092 07354 07577 07628
LAND BASED RADARS				
AN/TPS-59	1222.32 - 1392.56	2.9	-98.44	06992
AN/GPN-30 Airport Surveillance Radar	2702.6 – 2897.4 1090	1.06 8.4	-110 -85	07099/4
AN/TPN-22 Precision Approach Radar	9000-9200	2.5	-98	04150/2
SHIP BASED RADARS				
AN/SPN-35	9000 - 9160	7	-96.1	01542/4
AN/SPN-43	3590 - 3700			
AN/SPN-46	8800 – 9500 33,000 – 33,400	60 25	-85 -95	05797/2

6.0 UWB WAVEFORM PARAMETERS

There are several basic waveforms that are used for current UWB devices. These waveforms include both baseband and filtered baseband UWB signals. If a filtered waveform is used, the frequency band for the UWB signal shall be selected so the victim receiver operating band falls within the UWB signal band. If the waveform is generated by a baseband pulse, the selection of the frequency band does not apply.

The waveform characteristics have not been finalized, so it is not appropriate to specify the waveforms in detail at this point. However, it is possible to specify the waveform parameters relative to the receiver characteristics of the EUT. Several different UWB waveforms will be used, and it will be necessary to perform the tests for each waveform.

The UWB waveform parameters presented in this test plan are generic. The parameters used for testing a specific receiver will be based on the characteristics of the receiver under test. The UWB waveform parameters, in general, should be selected as shown below. The first five waveforms described below should provide the most EMI impact on a receiver. If none of the first five waveforms produce significant EMI impact on the EUT, the impact with other waveforms will be negligible and the testing can end at this

point. If any of the first five waveforms result in EMI, additional testing should be performed using waveforms 6 and 7 to provide a better characterization of the impact. However, it should be noted that Waveforms 6 and 7 will apply only to receivers with an IF bandwidth that is much lower than the maximum PRF of the UWB emitter, which is 100 MHz. Waveforms 6 and 7 will apply to receivers with IF bandwidths less than 1 MHz and will not apply to receivers with IF bandwidths equal to or greater than 10 MHz. For receivers with IF bandwidths between 1 MHz and 10 MHz the applicability of Waveforms 6 and 7 will depend on the receiver characteristics.

6.1.1 Test Waveform One (TW1)

For the first test waveform, the pulse repetition frequency (PRF) should be the maximum value available from the pulse generator that results in the fundamental or a harmonic of the PRF falling within the tuning range of the receiver. For example, if the receiver tunes from 225 MHz to 400 MHz, the maximum PRF available from the pulse generator (100 MHz) should be used. This would result in a third harmonic at 300 MHz that would fall within the tuning range of the receiver. However, if the receiver tunes from 30 MHz to 88 MHz the PRF should be slightly below 88 MHz (e.g., 85 MHz) so the fundamental falls within the tuning range of the receiver. For a receiver that tunes from 108 MHz to 174 MHz, a PRF of approximately 85 MHz would result in a second harmonic of the PRF at 170 MHz that is within the receiver tuning range. This first test waveform should not be dithered or modulated. For this case, the PRF will be fast compared to the receiver response time so the receiver IF will not respond to the individual pulses. Only one spectral line will fall within the intermediate frequency (IF) passband and the RF signal will appear to be a continuous wave (CW) signal. The victim receiver should be tuned to one of the spectral lines.

6.1.2 Test Waveform Two (TW2)

For the second test waveform, the basic PRF should be the same as described for the first test waveform. However, the pulses should be dithered randomly, to fill 25%, 50% or 100% of the IF passband. This will result in a noise like signal in the IF passband and the receiver should be tuned for maximum impact from the UWB signal.

6.1.3 Test Waveform Three (TW3)

For the third test waveform, the PRF should be equal to the IF bandwidth of the receiver and the pulses should be dithered randomly to fill 25%, 50% or 100% of the IF passband, but not the same amount of filling as used in TW2. This will result in a noise like signal across the tuning range of the receiver.

6.1.4 Test Waveform Four (TW4)

For the fourth test waveform, the PRF should be equal to the receiver IF bandwidth and the pulses should not be dithered but the waveform should be modulated with the type of modulation that is closest to that used for the desired signal (e.g., on-off keying [OOK])

for amplitude modulated signals and pulse position modulation [PPM] or swept dithering for frequency modulated signals). This type of interfering signal will result in a modulated signal in the IF passband and the UWB waveform should be tuned for a maximum impact in the receiver.

6.1.5 Test Waveform Five (TW5)

For the fifth test waveform, the PRF should be 0.10 of the receiver IF bandwidth and the signal should not be dithered or modulated. For this case, the PRF will be slow relative to the IF response time so that individual pulses will appear in the IF (however, the pulse width will be increased and the peak power will be reduced). For this waveform approximately 10 spectral lines will fall within the IF passband.

6.1.6 Test Waveform Six (TW6)

For the sixth test waveform, the PRF should be 10 times the receiver IF bandwidth or the highest UWB PRF not previously used which will result in a harmonic of the PRF in the receiver passband and the UWB pulses should not be dithered or modulated. For this case, the PRF will be fast relative to the IF response time. Therefore, the signal will appear to be continuous and the effect will be that of a CW signal. Only one spectral line can fall within the IF passband and the receiver should be tuned to that spectral line.

6.1.7 Test Waveform Seven (TW7)

For the seventh test waveform, the PRF should be 10 times the receiver IF bandwidth or the highest UWB PRF not previously used which will result in a harmonic of the PRF in the receiver passband and the pulses should be dithered randomly to fill 25%, 50% or 100% of the IF bandwidth but not the percentage of filling used in TW2 or TW3. This will result in a noise like signal in the IF passband and the UWB waveform should be adjusted for a maximum impact in the receiver.

7.0 CONDUCTED SUSCEPTIBILITY OF SELECTED RECEIVERS

The objective of the conducted susceptibility tests at the receiver antenna port is to obtain data that will provide useful information on the susceptibility of each of the selected receivers to representative UWB waveforms. Conducted susceptibility tests are preferred to radiated susceptibility tests because they will provide better control of test conditions and will minimize test time and test complexity. The approach that will be used is to subject each of the selected receivers to each of the UWB waveforms described above and determine the conditions that cause EMI effects in the receiver. The results of this task will define the receiver susceptibility threshold to these waveforms when the UWB emitter is connected directly to the receive antenna port (through a variable attenuator).

The requirements of these tests are to:

- determine UWB emission conditions that cause EMI effects in selected military radio systems; and
- determine the maximum UWB output power for each emission condition to ensure compatibility between UWB devices and selected military communication, radio-navigation, radar, and safety-of-life systems.

It should be noted that the in-band components of the UWB signal are the primary concern. Due to the wide diversity of subsystem designs being developed, the applicability of this type of requirement and appropriate limits need to be determined for each combination of UWB signals and receivers. Also, requirements need to be specified that are consistent with the signal processing characteristics of the subsystem and the particular test procedures to be used to verify the requirement.

This requirement is most applicable to fixed frequency, tunable, superheterodyne receivers. For other types of receivers (e.g., frequency hopping receivers), application of this requirement is less straightforward and care must be taken to ensure that any applied requirements are properly specified. If a frequency hopping receiver also has a mode of operation using a fixed frequency, both modes should be tested. Many receivers are designed to be interference or jam resistant and this feature may make application of this requirement difficult or inappropriate.

The antenna port susceptibility tests defined in this section are conducted tests in which the desired and/or interfering signals are injected directly into the receiver antenna port. Typical data for the EMI Test Report for receiver conducted susceptibility are the sensitivity of the receiver, the levels of the desired and interfering signal sources, frequency of the desired signal source and basic PRF of the UWB source, modulation of the desired signal and PRF or pulse amplitude modulation of the interfering signal, operating frequencies of the receivers, and frequencies and threshold levels associated with any responses.

Because of the large variety of UWB waveforms and receiver designs that exist, the requirements for the specific waveform and the operational characteristics of a receiver must be established before detailed test procedures can be developed. This test plan describes the general procedures that should be used. The basic concept with this test procedure is to apply EMI signals to the antenna port of the receiver while monitoring the receiver for degradation. Figure 1 depicts a general test setup for this test.

The tests are usually performed using either one or two signals. With the one signal tests, an interfering signal is input to the receiver under test and the receiver output is observed. The receiver is considered to be susceptible if the interfering signal produces a detectable

NETEX Test Master Plan
Draft 8/15/02

change in the receiver output. The modulation of the interfering signal is usually typical of the desired signal waveform that is normally used by the receiver. For UWB signals, the interfering signal waveform may be quite different from the intended signal waveform.

For the two signal tests, a desired signal at a level that will result in a standard response at the output of the receiver and the interfering UWB signal are both injected into the receiver. A standard response condition is based on a receiver performance parameter that can be measured at the output of the receiver. (e.g., signal-to-interference, noise, and distortion (SINAD), minimum discernable signal, or the bit error rate). The two signal source procedure is most appropriate for receivers that must be operating in a simulated normal manner during the tests. This would include receivers that must acquire and maintain synchronization for normal operation.

A receiver that requires synchronization to operate has two basic modes generally termed the acquisition/synchronization (A/S) mode and the tracking mode. Susceptibility thresholds for both A/S and tracking modes are required for a thorough electromagnetic compatibility (EMC) evaluation. Susceptibility thresholds are usually lower for the A/S mode than for the tracking mode. The antenna port conducted susceptibility Measurements should be performed, when appropriate, for receiver operation in both of these modes.

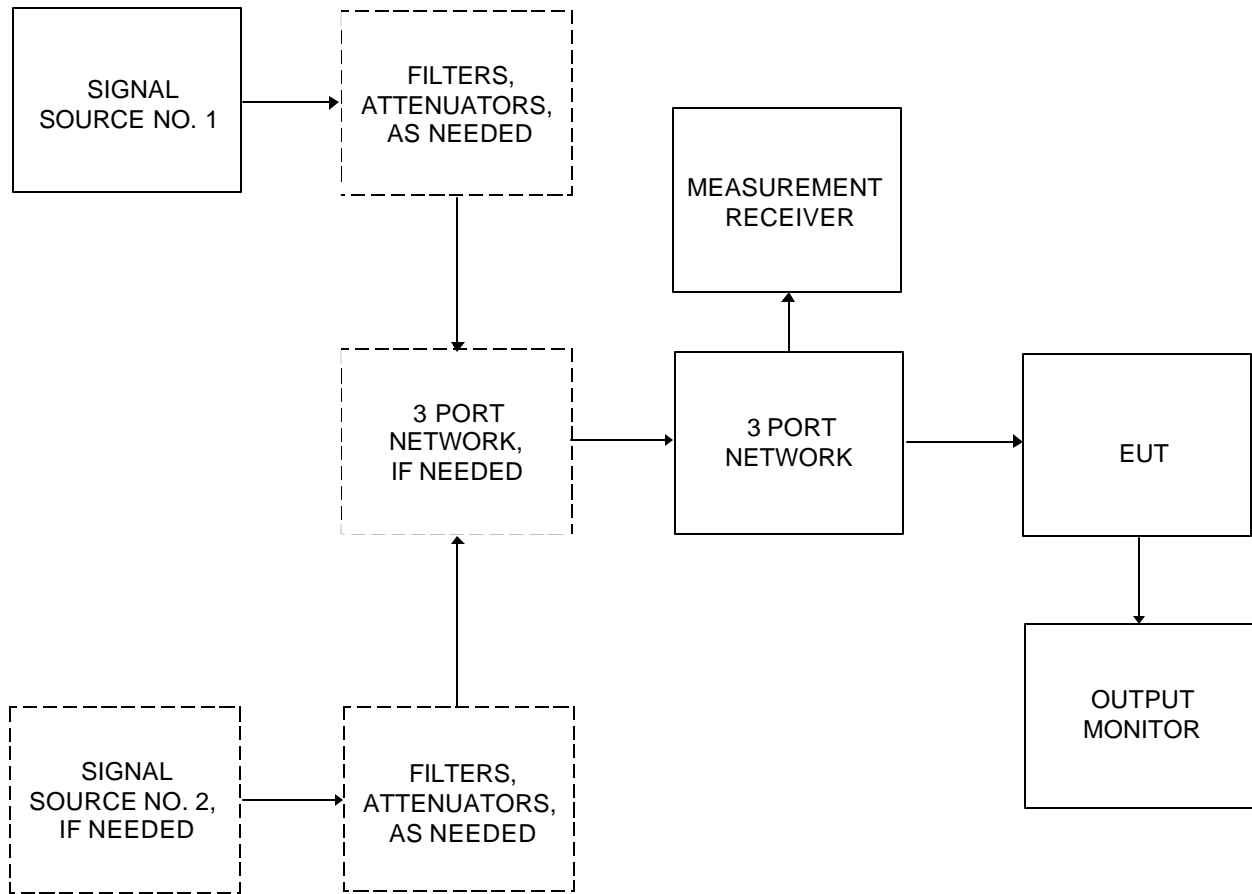

Figure 1. MIL-STD-461E CS104 General Test Setup.

If a receiver operates in several modes it should be tested using a sufficient number of the modes to obtain a reasonable characterization of the device. For example, if the receiver operates at several different data rates, usually, it is sufficient to test at high, medium, and low data rates (selected from the available data rates). If the victim EUT has three modes or less, all modes shall be tested.

The performance of these conducted susceptibility tests will require the use of a desired signal source which can be a transmitter or signal simulator test set designed for the system in which the receiver EUT operates. The transmitter or test set will be used to simulate the desired signal during the EMI tests.

The receiver upset threshold is the level at which the receiver performance parameter at the receiver output drops below the standard response level. Often, receivers will output data that will give indications related to the integrity of the received signal. This data may provide indications verifying acceptable code lock, carrier lock, detector lock, signal-to-noise ratio (S/N), and automatic gain control (AGC) performance. An unacceptable indication of one or more of these parameters can be used as an upset criteria when the

degradation corresponds to the activation or increase in power level of an interfering signal.

Another method for determining degradation due to EMI is to monitor the bit error rate (BER) of the receiver output data message. The BER monitor compares the injected information data message at the receiver input to the detected message data at the receiver output. An EMI upset can be defined as occurring when the receiver bit error rate exceeds the maximum allowable limit for the system (and BER degradation corresponds to the activation of the interfering signal).

The receiver antenna should not be included as part of the EUT for the conducted tests. However, any external receiver system components such as external RF filters or (in the case of a transponder) a diplexer, should be included as part of the receiver EUT. It is expected that most receiver systems can be tested using a conducted test signal technique.

If a receiver design includes an integral antenna (i.e., the antenna cannot be detached from the receiver electronics to allow direct signal injection) or an antenna module that contains filters, pre-amplifiers, and/or mixers, it may be necessary to perform the receiver tests using a radiated method. This is a more complicated Measurement in which all test signals are radiated and care must be taken to verify that all observed responses are due to the equipment under test and not generated by the test equipment or facility. The conducted signal Measurements detailed in this document can be converted to radiated methods with proper consideration of test areas (anechoic chambers) and antenna parameters such as polarization, gain, and pointing angle. In general, tests performed using radiated signal techniques are more difficult to control, monitor, and obtain verifiable results in comparison to tests performed using conducted signal methods.

7.1 Receiver Sensitivity Measurement

The receiver sensitivity level is specified as the signal level required to create an appropriate standard response that results in satisfactory operation of the receiver. It is recommended that the receiver standard response be at a level that is 3 to 10 dB above the receiver noise level (e.g., the standard response may be the level that results in a SINAD equal to 10 dB). Specifications for receiver sensitivity are typically available from the receiver manufacturer but they should be verified by independent test to demonstrate that the receiver is operating properly. In addition, the sensitivity measurement can be used as a validation of the test setup, procedures, and calibration methods. Therefore, it is advantageous to verify the receiver sensitivity specifications as part of the EMI tests. It should be noted that there are a number of different performance parameters that are used to specify receiver sensitivity. The standard response is usually specified relative to a performance threshold of the receiver. Examples of parameters used to specify standard responses are SINAD, BER, MDS, acquisition threshold, upset threshold, etc.

The receiver sensitivity is measured using an on-tune desired signal that contains the normal receiver modulation. The sensitivity threshold levels for receivers may vary for

different modes of operation of the receiver (e.g. different data rates). Also, for receivers that require synchronization for normal operation, it is typical that the acquisition of synchronization (A/S) mode sensitivity threshold level is higher than the tracking mode sensitivity level (i.e., the signal level required to obtain synchronization is usually higher than the level required to maintain synchronization after the signal has been acquired).

7.1.1 Receiver Sensitivity Test Objective

The objective of this test is to measure the receiver sensitivity. Receiver sensitivity is the minimum signal level at the input to the victim receiver necessary to achieve the receiver's standard response as provided in receiver technical literature (i.e., 10 dB SINAD, acceptable BER, acquisition of synchronization, MDS, etc).

7.1.2 Receiver Sensitivity Test Setup

The test setup diagram for the receiver sensitivity test is shown in Figure 2. A signal simulator is used to generate the data and/or the standard response signal used for the test. A spectrum analyzer is used to monitor and measure the signal level at the input to the receiver EUT. A pre-amplifier connected at the input of the spectrum analyzer may be required to observe the signal during the sensitivity test. Alternatively, after the sensitivity level is established, the signal level can be raised by a known, fixed amount (e.g., 40 dB) to enable the spectrum analyzer measurement to be made.

Measured spectrum analyzer levels should be corrected for the pre-amplifier gain (if used) plus coupler and/or cable losses that exist in the measurement system. The level to be recorded is the signal level at the input to the EUT receiver, not the level of the same signal at the output of the signal simulator. The receiver operation is verified to be satisfactory by monitoring the receiver output and/or measuring the desired receiver standard response.

7.1.3 Receiver Sensitivity Test Procedure

The general test procedure for determining receiver sensitivity is as follows:

1. Set the desired signal simulator to its minimum output power level. Set the simulator output frequency to the tuned frequency of the receiver. Modulate the simulated signal in the normal manner used by the receiver and, if appropriate, coded with the receiver's internal code. Verify that the receiver has not achieved a standard response condition for the low level signal.
2. Increase the signal simulator power level until the receiver standard response level is obtained (i.e., 10 dB SINAD, acceptable BER, acquisition of synchronization, MDS, etc). Pause after each increase in signal power for a period exceeding the maximum specified settling time for the receiver. A receiver standard response condition corresponds to a condition in which all receiver "health indications" (such as code lock, carrier lock, data detector lock,

S/N ratio, and BER) are within acceptable limits. Record the input power level at which the standard response condition was first observed on the data sheet (Table 3). This power level is defined as the “standard response acquisition threshold” (ACQ).

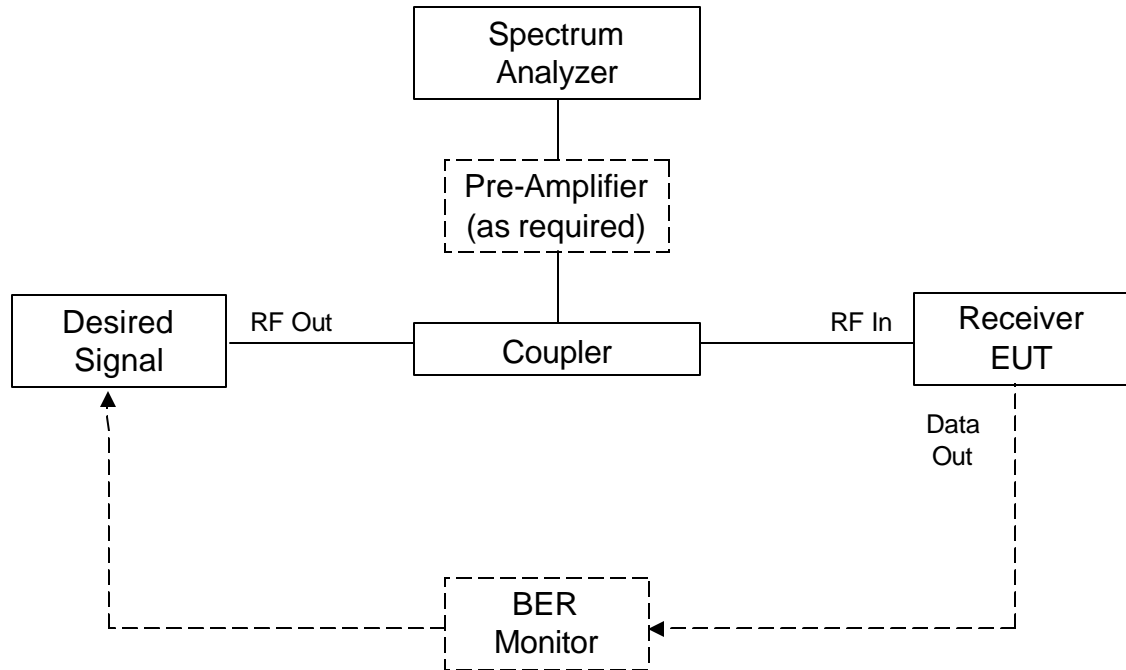

Figure 2. Receiver Sensitivity Test Set-Up

3. Increase input power level an additional 10 dB above the ACQ.
4. Decrease the input power level until the standard response condition is impacted. Record on the data sheet (Table 3) the input power level at which loss of the standard response was first observed. This level is termed the “signal upset threshold” (SUPSET) level. It should be noted that ACQ and SUPSET will occur at the same level for some types of receivers. However, for other types of receivers, such as those that require synchronization, loss of carrier lock is the first indicator of received signal degradation and this condition will usually occur at signal levels that are below ACQ.
5. Repeat steps 1 through 4 at least three times to determine the ACQ and SUPSET levels more precisely. The level recorded on the data sheet should be the average level achieved. If either set of these levels vary by more than 3 dB, repeat the measurements a sufficient number of times to determine a set of levels for both ACQ and SUPSET.
6. Steps 1 through 5 should be performed at frequencies corresponding to 10%,

50% and 90% of the tuning band.

7. If the receiver has multiple modes, repeat Steps 1 through 6 while the receiver is operating at several representative modes (e.g., if the receiver operates at several data rates, make the measurements with the receiver operating at minimum, maximum, and nominal data rates). Each fully unique mode or set of modes must be tested (i.e., AM, FM, and frequency hopping).

**TABLE 3
DATA SHEET FOR SENSITIVITY MEASUREMENTS**

Receiver:
Frequency Band(s):
Receiver Modes:
Test Frequencies:
Standard Response Criterion:
Desired Signal Modulation:
IF Bandwidth:
Sensitivity:

RCVR FRQ (MHz)	RCVR MODE	ACQ (dBm)	SUPSET (dBm)	NOTES

NOTE: Sensitivity threshold levels are inherently statistical and thus this procedure should be conducted multiple times to obtain a representative sample of the threshold level. Tests should be conducted at frequencies corresponding to 10%, 50% and 90% of the tuning band.

7.1.4 Receiver Sensitivity Test Output

The required results from the receiver sensitivity test consist of recording the ACQ and the SUPSET at a representative number of modes of operation. An average threshold value should be specified if significant differences exist between the thresholds

determined in the multiple test trials. ACQ levels and SUPSET levels, for use in the subsequent tests, shall be determined based on these measured sensitivity levels.

7.2 White Noise Measurement

The white noise susceptibility Measurement is performed by injecting a desired signal and a white noise signal, with the same or greater bandwidth as that of the victim receiver, directly into the receive antenna port and observing the impact at the output of the receiver.

The white noise source shall be a Noise/Com model UFX 7112, or equivalent, for EUT operating at frequencies of 2 GHz or less. For EUT operating at frequencies above 2 GHz, the source shall be a Noise/Com model UFX 7218, or equivalent. If the inband power out of the noise source is not sufficient to produce the desired effect(s), a low noise amplifier with sufficient gain to produce the desired results and sufficient bandwidth to cover the entire band of the EUT shall be used. The gain and flatness of the amplifier in combination with the white noise source across the EUT operating band shall be measured with a spectrum analyzer and recorded as part of the EUT test data. The spectrum analyzer resolution bandwidth (RBW) shall be set to the value closest to but less than that of the most narrow receiver IF filter. The analyzer video bandwidth (VBW) shall be equal to or greater than (\geq) the RBW. The data shall be shown in a plot of frequency versus measured power with one line plotted for the unamplified white noise source and one lined plotted for the amplified white noise.

7.2.1 White Noise Test Objective

The objectives of this test are to determine the impact of white noise signals on a receiver and to determine the susceptibility threshold as a function of the white noise signal parameters.

7.2.2 White Noise Test Setup

The test setup is shown in Figure 3.

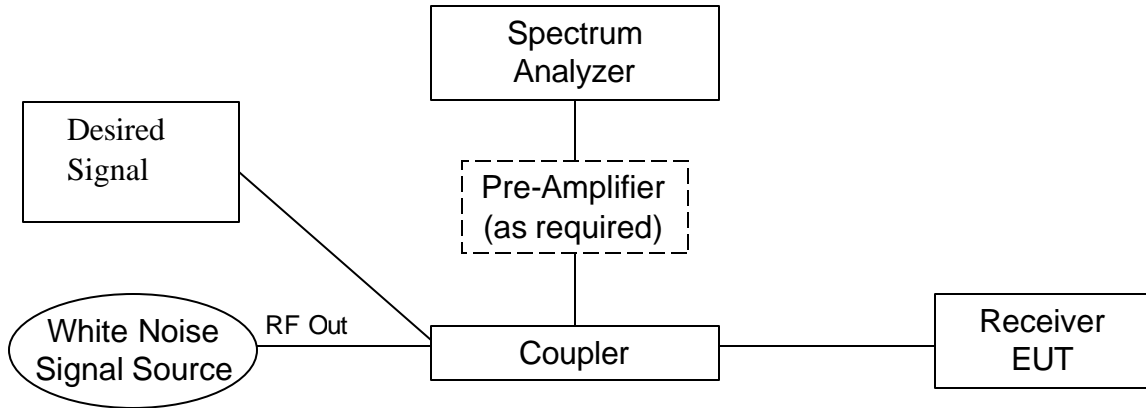

Figure 3. Setup for White noise Susceptibility Test

7.2.3 White Noise Test Procedure

1. Input the desired signal at the standard response level.
2. Inject the white noise signal into the receiver input at a level that is at least 10 dB above the receiver standard response level. The noise level should be high enough to mask the desired signal at the receiver output. The average noise level should be measured using the spectrum analyzer with a resolution bandwidth of 1 kHz, 30 kHz or 1 MHz (or similar bandwidths). The bandwidth should be selected so it is the highest of the three choices that is less than the receiver IF bandwidth. Empirical or calculated bandwidth correction factors should be used to adjust the readings to the IF bandwidth of the receiver. Increase the desired signal level to obtain a standard response condition. Record the desired and interfering signal levels on the data sheet Table 4.

TABLE 4
DATA SHEET FOR WHITE NOISE TESTS

Receiver:
Frequency Band(s):
Receiver Modes:
Test Frequencies:
Standard Response Criterion:
Desired Signal Modulation:
IF Bandwidth:
Sensitivity:

	SIGNAL LEVEL (dBm)	NOISE LEVEL (dBm)
STANDARD RESPONSE LEVEL		N/A
LEVEL WHERE NOISE MASKS SIGNAL		
STANDARD RESPONSE LEVEL WITH NOISE		

7.2.4 White Noise Test Output

The test output will define white noise waveform conditions that result in EMI.

7.3 One Signal Susceptibility Measurement

The one signal susceptibility Measurement is performed by injecting a UWB signal, with the appropriate waveform parameters as defined in Section 6.0, directly into the receive antenna port and observing the impact at the output of the receiver. If the receiver exhibits a change in the output as a result of the injected interfering signal, the receiver is considered to be susceptible. The change in the output may be manifested as a change in the output noise, the production of an interfering signal at the receiver output, activation of the receiver automatic gain control, etc.

7.3.1 One Signal Susceptibility Test Objective

The objectives of this test are to determine the impact of UWB signals on a receiver and to determine the susceptibility threshold as a function of the UWB signal parameters.

7.3.2 One Signal Susceptibility Test Setup

The test setup is shown in Figure 4.

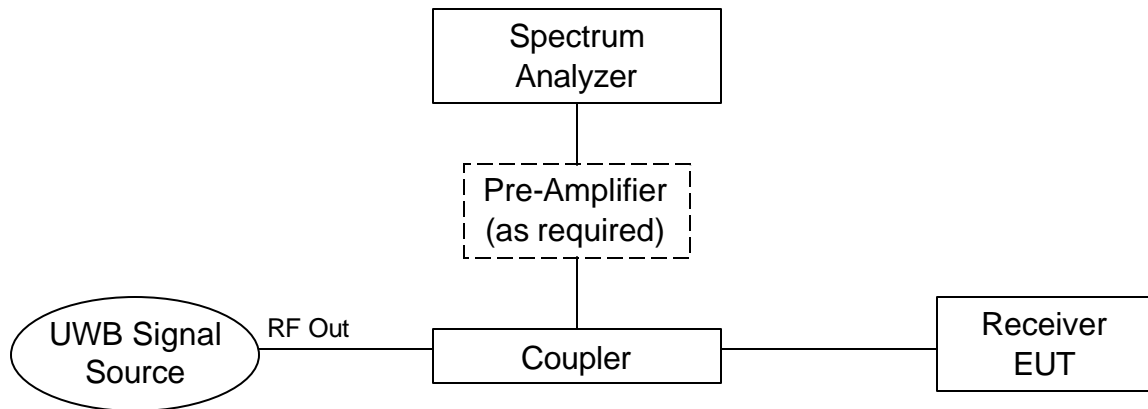

Figure 4. Setup for One Signal Susceptibility Test

7.3.3 One Signal Susceptibility Test Procedure

The procedure is to inject a UWB signal into the receiver input and observe the receiver output for any change that may provide an indication of susceptibility. Examples of indications of susceptibility are changes in the output noise, the production of an interfering signal response at the output, activation of the receiver automatic gain control, etc. The tests should be conducted for each of the applicable UWB waveforms identified in Section 6.0. The UWB interference conditions, “interfering signal upset threshold” (IUPSET), that provided an indication of susceptibility should be recorded in Table 5.

Note that the spectrum analyzer resolution and video bandwidths will not be as wide as the RF bandwidth of the UWB waveform. It is recommended that the resolution bandwidth of the spectrum analyzer be 1 kHz, 30 kHz or 1 MHz if possible. The bandwidth for a specific application should be selected such that it is the largest of the three choices that is less than the IF bandwidth under test. Empirical or calculated bandwidth correction factors should be used to adjust the measurement of the UWB waveform to the IF bandwidth of the receiver. Average measurements should be made for all of the test waveforms except for Waveform 5 which should be made as a peak measurement. Also, if the receiver has multiple modes of operation, the tests should be performed for each mode or a representative set of the modes of operation as described in

section 7.1.3 step 7. Record the interfering signal conditions (signal parameters and levels) that cause an impact on the receiver output.

7.3.4 One Signal Susceptibility Test Output

The test output will define UWB waveform conditions that result in EMI.

TABLE 5
ONE SIGNAL SUSCEPTIBILITY TEST RESULTS

Receiver:
Frequency Band(s):
Receiver Modes:
Test Frequencies:
Standard Response Criterion:
Desired Signal Modulation:
IF Bandwidth:
Sensitivity:

RX FRQ (MHz)	UWB SIGNAL	PRF (PPS)	UWB MOD	IUPSET (dBm)
	1		NONE	
	2		DITHERED	
	3		DITHERED	
	4		MODULATED	
	5		NONE	
	6		NONE	
	7		DITHERED	

7.4 Two Signal Susceptibility Measurement

The two signal susceptibility tests described in this test plan require that the receiver desired signal and potential UWB interference signal be simultaneously injected into the receiver antenna port. There are two approaches that may be used to determine the receiver susceptibility.

For the first approach, the desired signal level is fixed at or above the standard response

level as determined in Section 7.1.4 above and the susceptibility of the receiver to an UWB signal is determined.

For the second approach, a high level UWB signal is injected and the desired signal level that is required for satisfactory operation of the receiver is determined. The information obtained from this test may be used to determine the reduction in range that the receiver will experience as a result of the interference.

The tests should be conducted for each of the waveforms identified in Section 6.0. Note that the spectrum analyzer resolution bandwidths may not be as wide as the RF bandwidth of the UWB waveforms. It is recommended that the resolution bandwidth of the spectrum analyzer be 1 kHz, 30 kHz or 1 MHz. The resolution bandwidth used to measure a specific receiver should be selected so that it is the largest of the three choices that is less than the receiver IF bandwidth. Empirical or calculated bandwidth correction factors should be used to adjust the measurement of the UWB waveforms to the IF bandwidth of the receiver. Average measurements should be made for all of the test waveforms except for Waveform 5 which should be made as a peak measurement.

7.4.1 Two Signal Susceptibility Tests for Desired Signal at Standard Response Level

This test is conducted with a desired signal that is at the standard response level of the receiver and an UWB interfering signal at a level that impacts the standard response condition.

7.4.1.1 Two Signal Susceptibility Tests for Desired Signal at Standard Response Level Test Objective

The objective of the two signal EMI tests is to determine the susceptibility of a receiver operating with a desired signal at the standard response level to UWB interfering signals. Susceptibility thresholds are determined by monitoring the output of the receiver for changes in the standard response that indicate the presence of an interfering signal.

7.4.1.2 Two Signal Susceptibility Tests for Desired Signal at Standard Response Level Test Setup

The test setup is shown in Figure 5.

7.4.1.3 Two Signal Susceptibility Tests for Desired Signal at Standard Response Level Test Procedure

The general test procedure for determining receiver susceptibility to interference when the desired signal is at the standard response level is described below.

1. Set the desired signal to a selected test frequency and adjust the output power to a level that is 6 dB above the ACQ as measured in Section 7.1.3. The desired signal should be modulated in the normal manner used by the receiver and, if appropriate, coded with the receiver's internal code. The test frequency should be

selected to provide a maximum EMI condition for the UWB waveform being used for the tests. Tune the receiver to the test frequency and verify that the receiver output exceeds a standard response condition.

2. Decrease the desired signal until the level is 6 dB above the SUPSET as measured in Section 7.1.3. Record this level in Table 6 as the “desired signal” level (DSL) in the first row for the specified UWB PRF. Verify that the receiver output exceeds a standard response condition.

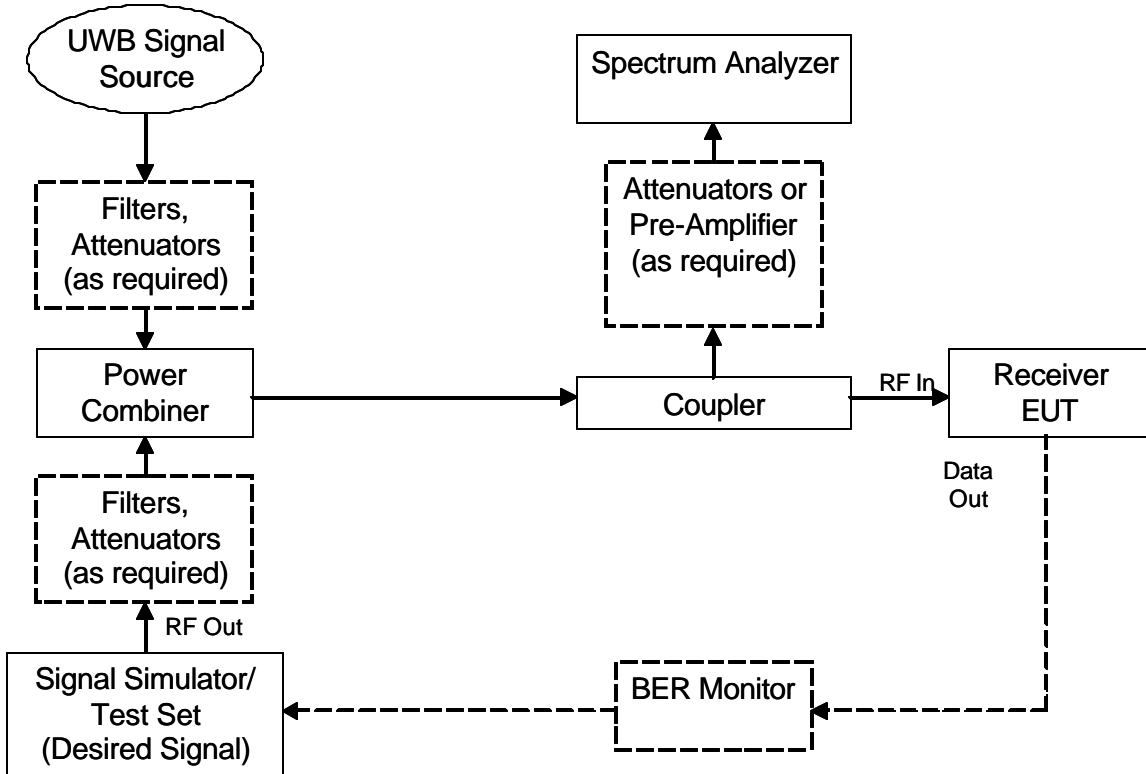

Figure 5. Setup for Two Signal Susceptibility Tests

3. Activate the UWB interference signal source with one of the UWB test waveforms at a level that is 20 dB below the “desired signal upset threshold” level.
4. Increase the UWB interference power until there is an indication of impact on the receiver standard response condition. The impact could be a decrease in the SINAD, an increase in the BER, loss of receiver synchronization, etc. The receiver should be operating at a frequency that results in a maximum EMI condition for the UWB signal. Record this level in Table 6 as the IUPSET level. Record IUPSET – DSL as the “interference to signal ratio” (I/S).

*NETEX Test Master Plan
Draft 8/15/02*

5. Set the desired signal level to 6 dB above the acquisition threshold level. Record this level in Table 6 as the DSL in the second row for the specified UWB PRF. Set the UWB interfering signal to the maximum level available. Decrease the UWB interference signal power until the receiver returns to a standard response condition and all parameters are within acceptable limits. Record this interference level in Table 6 as the “interfering signal reacquisition threshold” (REACQ) level. Record REACQ – DSL as the I/S.
6. Repeat Steps 1 through 5 for each of the UWB test waveforms.
7. Repeat Steps 1 through 6 for different receiver operating frequencies and for different modes of operation.

**TABLE 6
DESIRED SIGNAL AT STANDARD RESPONSE LEVEL SUSCEPTIBILITY
TEST RESULTS**

Receiver:
Frequency Band(s):
Receiver Modes:
Test Frequencies:
Standard Response Criterion:
Desired Signal Modulation:
IF Bandwidth:
Sensitivity:

RX FRQ (MHz)	UWB SIGNAL	PRF (PPS)	UWB MOD	DSL (dBm)	IUPSET (dBm)	REACQ (dBm)	I/S (dB)
	1		NONE			X	
	1		NONE		X		
	2		DITHERED			X	
	2		DITHERED		X		
	3		DITHERED			X	
	3		DITHERED		X		
	4		MODULATED			X	
	4		MODULATED		X		
	5		NONE			X	
	5		NONE		X		

RX FRQ (MHz)	UWB SIGNAL	PRF (PPS)	UWB MOD	DSL (dBm)	IUPSET (dBm)	REACQ (dBm)	I/S (dB)
	6		NONE			X	
	6		NONE		X		
	7		DITHERED			X	
	7		DITHERED		X		

7.4.1.4 Two Signal Susceptibility Tests for Desired Signal at Standard Response Level Test Output

The results from the Two Signal Tests for Desired Signal at Standard Response Level will define the interfering signal levels (or the I/S ratios) for the “desired signal levels,” the “upset thresholds,” and the “reacquisition threshold” for all interference signal modulations and receiver modes that are tested.

7.4.2 Two Signal Susceptibility Test With High Level UWB Signal

This test is conducted with a High Level UWB signal (e.g., 20dB above the receiver sensitivity) and a desired signal level that results in a standard response condition at the output of the receiver.

7.4.2.1 Two Signal Susceptibility Test With High Level UWB Signal Test Objective

The objective of this test is to determine the impact of a High Level UWB signal on a receiver. The tests will determine the desired signal level that is required for the receiver to operate in a satisfactory manner with a High Level UWB signal present.

7.4.2.2 Two Signal Susceptibility Test With High Level UWB Signal Test Setup

The test setup is the same as the setup shown in Figure 5. The only differences between this test and the previous test (i.e., the Two Signal Susceptibility Test with the desired signal set at a standard response level) are the levels of the desired and interfering signals.

7.4.2.3 Two Signal Susceptibility Test With High Level UWB Signal Test Procedure

The general test procedure for determining the desired signal level required for satisfactory operation when a High Level UWB signal is present is as follows:

1. Select a set of waveform parameters from the list described in Section 6. Adjust the UWB signal to a level that is 20 dB above the receiver standard response. Record this level as the Interference Signal Level (ISL) in Table 7.

NETEX Test Master Plan
Draft 8/15/02

2. Increase the desired signal level until the receiver achieves a standard response condition. Record the desired signal level for ACQ in Table 7. Record ACQ – ISL as the desired signal to interference ratio (S/I) in Table 7.
3. Decrease the desired signal level until upset occurs. Record the UPSET in Table 7. Record UPSET – ISL as the desired S/I ratio in Table 7.
4. Repeat Steps 1 through 3 for each of the UWB waveforms and for different receiver frequencies and operating modes.

TABLE 7
TWO SIGNAL SUSCEPTIBILITY TEST WITH HIGH LEVEL UWB SIGNAL
TEST RESULTS

Receiver:
Frequency Band(s):
Receiver Modes:
Test Frequencies:
Standard Response Criterion:
Desired Signal Modulation:
IF Bandwidth:
Sensitivity:

RX FRQ (MHz)	UWB SIGNAL	PRF (PPS)	UWB MOD	ISL (dBm)	ACQ (dBm)	UPSET (dBm)	S/I (dB)
	1		NONE			X	
	1		NONE		X		
	2		DITHERED			X	
	2		DITHERED		X		
	3		DITHERED			X	
	3		DITHERED		X		
	4		MODULATED			X	
	4		MODULATED		X		
	5		NONE			X	
	5		NONE		X		
	6		NONE			X	
	6		NONE		X		

RX FRQ (MHz)	UWB SIGNAL	PRF (PPS)	UWB MOD	ISL (dBm)	ACQ (dBm)	UPSET (dBm)	S/I (dB)
	7		DITHERED			X	
	7		DITHERED		X		

7.4.2.4 Two Signal Susceptibility Test With High Level UWB Signal Test Output

The results from the two signal EMI tests define the desired and interfering signal levels for the “acquisition threshold,” the “upset threshold,” and the “reacquisition threshold” for all interference signal modulations and receiver modes that are tested.

8.0 RADIATED SUSCEPTIBILITY OF SELECTED RECEIVERS/SYSTEMS

For receiver/system level radiated testing, MIL-STD-464 will be used as a guide. According to MIL-STD-464, the receiver/system must exhibit electromagnetic compatibility (EMC) among all subsystems and equipment within the system and with environments caused by electromagnetic effects external to the system. Safety critical functions shall be verified to exhibit EMC within the system and with external environments prior to use in those environments.

The radiated testing will be performed to demonstrate the impact of UWB emitters on overall system performance of critical receivers when operating in their normal operating electromagnetic environment (EME). The radiated susceptibility test for a single UWB emitter will be similar to the conducted test. The major difference will be that the coupling from the signal sources will be radiated instead of conducted. The receivers and waveform parameters to be used for radiated tests using multiple UWB emitters will be determined from the results of the conducted tests.

The following list provides guidance on issues which should be addressed for inter-system EMC testing:

- Potential interference source versus victim pairs should be systematically evaluated. Both one source versus a victim and multiple sources versus a victim conditions need to be considered.
- A frequency selection plan should be developed for exercising antenna-connected transmitters and receivers. This plan should include:
 - Predicable interactions between transmitters and receivers such as transmitter harmonics, intermodulation products, other spurious responses (such as image frequencies), and cross modulation. The acceptability of certain types of responses will be system dependent.

NETEX Test Master Plan
Draft 8/15/02

- Evaluation of transmitters and receivers across their entire operating frequency range, including emergency frequencies.
- Testing should be conducted in an area, such as an anechoic chamber, where the electromagnetic environment does not affect the validity of the test results. The most troublesome aspect of the environment is usually dense utilization of the frequency spectrum, which can hamper efforts to evaluate the performance of antenna-connected receivers with respect to noise emissions of other equipment installed in the system.

A common issue in EMC testing is the use of instrumentation during the test. The most common approach is to monitor subsystem performance through visual and aural displays and outputs. It is usually undesirable to modify cabling and electronics to monitor signals to assess subsystem performance, since these modifications may change subsystem responses and introduce additional coupling paths.

Some antenna-connected receivers, such as airborne instrument landing systems and identification of friend or foe (IFF), require a baseline input signal (set at required performance levels) for degradation to be effectively evaluated. Other equipment that transmits energy and evaluates the return signal, such as radars or radar altimeters, need an actual or simulated return signal to be thoroughly assessed for potential effects.

The need to evaluate antenna-connected receivers across their operating ranges is important for proper assessment. It has been common in the past to check a few channels of a receiver and conclude that there was no interference. This practice was not unreasonable in the past when much of the potential interference was broadband in nature, such as brush noise from motors. However, with the UWB waveforms, the narrowband spectral components of these signals may interfere with the receivers. Where possible, monitor antenna-connected outputs with spectrum analyzers during these EMC tests. Analysis of received levels is necessary to determine the potential for degradation of a particular receiver. Where possible, spectrum analyzers should be connected to unused, collocated antennas operating in the same frequency band(s) as the intended victim equipment. In some cases the substitution method of measuring the interfering signal environment is preferable to direct monitoring during the actual interference tests.

(In the substitution method, the actual victim equipment is replaced by a spectrum analyzer and the external EME is measured, both with the intended interference sources operated in the same manner as intended during the actual EMC tests and without the intended interferers. In this way the effect of the intentional interferers on the environment can be monitored without interfering with the normal operation of the potential victims.)

RF compatibility between antenna-connected transmitters and receivers is an element of intra-system electromagnetic compatibility and demonstration of compliance with that requirement needs to be integrated with these efforts. Any blanking techniques (for example on the EW systems) required for EMC should be included. (While this requirement is not part of the actual UWB radiated susceptibility tests, its accomplishment must be demonstrated prior to commencement of the UWB radiated susceptibility tests in order to eliminate these distracters from the potential interference matrix.

Performance degradation of antenna-connected communication receivers cannot be effectively assessed by simply listening to open channels. Squelch break has often been used as the criteria for failure. There are a number of problems with this technique.

If an intentional signal above the squelch is present, the type of degradation is dependent on the location of the interfering signal with respect to the carrier. If the interfering signal is within a few hundred hertz of the carrier, the main effect will probably be a change in the automatic gain control (AGC) level of the receiver. If the interfering signal is far enough from the carrier to compete with the sideband energy, much more serious degradation can occur. This condition gives the best example of why squelch break is not an adequate failure criterion.

AM receivers are typically evaluated for required performance using a 30%-AM, 1-kHz tone which is considered to have the same intelligibility for a listener as typical 80%-AM voice modulation. The total power in the sidebands is approximately 13 dB below the level of the carrier. Receiver specifications also typically require 10 dB (signal plus noise-to-noise $[S+N/N]$) ratios during sensitivity demonstrations. Therefore, an interfering signal which competes with the sidebands must be approximately 23 dB below the carrier in order to avoid interfering with receiver performance. An impact of this conclusion is that an interfering signal which is well below squelch break can cause significant range degradation in a receiver. If squelch break represents the true sensitivity required for mission performance, an interfering signal just below squelch break can cause over a 90% loss in potential range.

EMC testing should be performed under laboratory conditions where the system under test and the simulated environment are controlled. Undesired system responses may require an electromagnetic vulnerability (EMV) analysis to determine the impact of the laboratory observed susceptibility on system operational performance. Under unusual circumstances system susceptibilities may be investigated by operational testing in the actual external EME. There is much less control on variable conditions, fewer system functions can generally be exercised, and expenses can be much greater. The results of the EMV analysis and operational testing guide the possible need for system modification, additional analysis or testing.

Typically, 4 to 6 positions are used for low frequency illumination and 12 to 36 positions are used for spot illumination at higher frequencies. The emitters are radiated

sequentially in both vertical and horizontal polarization. Circular and cross polarization are usually not practical test radiators.

In general, the following measurements need to be performed.

- Measure at the input to the receiver the signal resulting from operation of on board transmitters without UWB transmitters.
- Measure at the input to the receiver the signal resulting from operation of on board transmitters with one or more UWB transmitters.
- Measure receiver susceptibility to these combined waveforms.

8.1 Radiated Susceptibility of Selected Receivers to a Single UWB Emitter

8.1.1 Radiated Susceptibility of Selected Receivers to a Single UWB Emitter Test Objective

The objective of these measurements is to determine if radiated emissions from a single UWB source will cause EMI effects in a receiver.

8.1.2 Radiated Susceptibility of Selected Receivers to a Single UWB Emitter Test Set-up

The test set-up diagram is shown in Figure 6 (page 32).

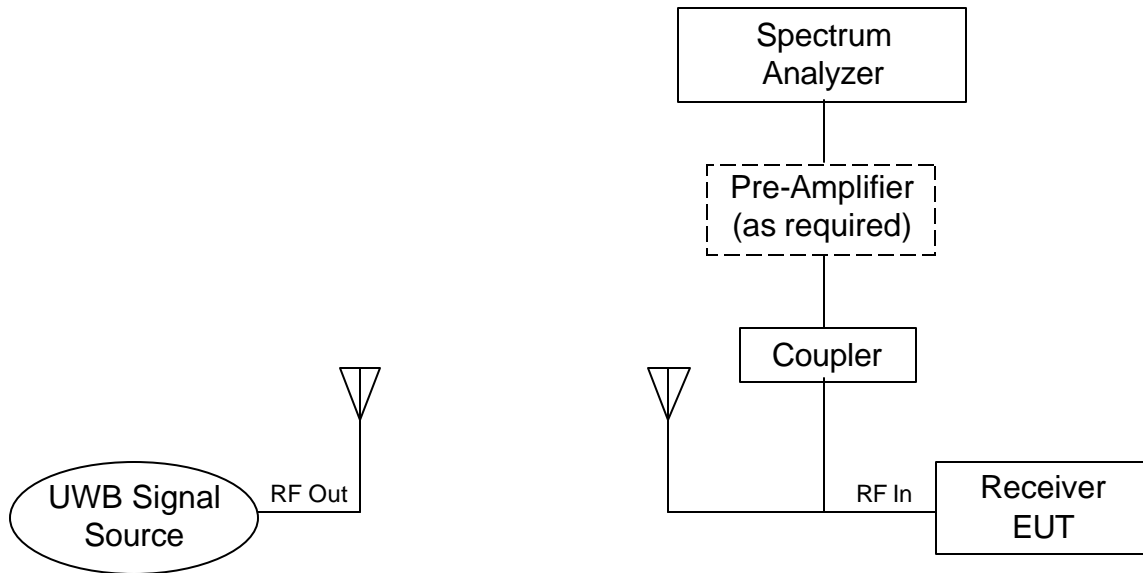

Figure 6. Radiated Susceptibility Test Set-Up-One Signal Method

8.1.3 Radiated Susceptibility of Selected Receivers to a Single UWB Emitter Test Procedure

The tests will be performed as described below.

1. Use the criteria for susceptibility defined above for conducted susceptibility tests.
2. Define the UWB waveforms for tests (use pulse width, pulse repetition rate, peak power defined above for conducted tests). Use conducted test results to calculate effective radiated power, or source/victim separation when source output power is fixed, required to cause radiated interference.
3. Connect the UWB emitter to its antenna and locate at a distance from the receive antenna that will cause interference, if possible, at the receiver under test.
4. Measure UWB signal input to receiver (i.e., at output of the receive antenna port or at receiver input port and note which used).
5. Measure receiver susceptibility threshold to these waveforms when the UWB emitter is radiating.
6. Perform basic one signal EMI susceptibility measurements without a desired signal (e.g., measure increase in output interference to noise ratio)

7. Perform two signal EMI susceptibility measurements with a desired and UWB interfering signal (e.g., measure impact on performance)

8.1.4 Radiated Susceptibility of Selected Receivers to a Single UWB Emitter Test Output

The test output will consist of performance measurements that should include impact on ability to acquire synchronization (if applicable) and impact on performance when synchronized (e.g., BER or Break Lock).

8.2 Radiated Susceptibility to Multiple UWB Emitters

8.2.1 Radiated Susceptibility to Multiple UWB Emitters Test Objective

The objective of these measurements is to determine if emissions from multiple UWB transmitters can have an aggregate or cumulative effect at a receiver IF output when multiple UWB signals are present at a receiver input. This information will also be applied to the aggregate modeling and analysis efforts.

These aggregate measurements will be conducted as closed-system tests using up to three UWB simulators.

8.2.2 Radiated Susceptibility to Multiple UWB Emitters Test Set-Up

Figure 7 shows the aggregate effects measurement test set-up.

8.2.3 Radiated Susceptibility to Multiple UWB Emitters Test Procedure

Tests will be made with signal combinations such as those shown in Table 6. For purposes of Table 6, VBW refers to the minimum IF filter bandwidth for the victim receiver.

1. Use the criteria for susceptibility defined above.
2. Define combinations of UWB waveforms for tests. Waveforms that caused an impact during the conducted tests will be selected. **DO NOT REPEAT THE SAME WAVEFORM ON MULTIPLE EMITTERS.**
3. Measure combined UWB signal emissions at input to receiver (i.e., at output of receive antenna port).
4. Emission measurements should include both time domain and frequency domain.
5. Measure receiver susceptibility to these combined waveforms

6. Perform multiple signal EMI susceptibility measurements without a desired signal (e.g., measure increase in output interference to noise ratio)
7. Perform multiple signal EMI susceptibility measurements with a desired and multiple UWB interfering signals (e.g., measure impact on performance).

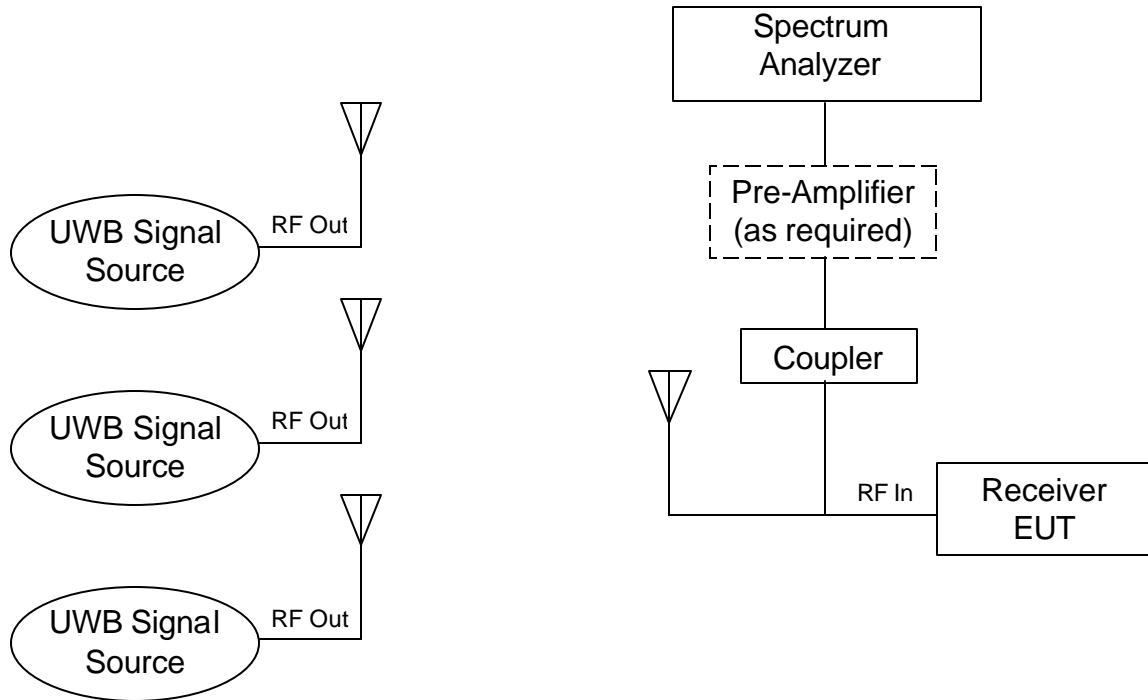

Figure7. Radiated Susceptibility Test Set-Up-Multiple Signal Method

8.2.4 Radiated Susceptibility to Multiple UWB Emitters Test Output

Test output will consist of characterization of radiated susceptibility of selected receivers to multiple UWB emitters when other on-board transmitters are also operating.

TABLE 6
EXAMPLE OF UWB PARAMETERS FOR AGGREGATE MEASUREMENTS
(The Specific Parameters Need to Be Determined after the Conducted and Radiated
Tests Have Been Performed on Single UWB Signals.)

TEST #	SIGNAL #	PRF	DITHER (%)	MOD.	RECEIVER IF OUTPUT RESPONSE TO UWB SIGNAL
1	1	Maximum	Yes (50%)	TBD	Noise-like
	2	10 X VBW	Yes (50%)	TBD	Noise-like
	3	VBW	Yes (50%)	TBD	Noise-like
2	1	Maximum	No	TBD	CW-like ¹
	2	10 X VBW	No	TBD	CW-like ¹
	3	VBW	No	TBD	CW-like ¹
3	1	VBW/10	No	TBD	Pulse-like
	2	VBW/3	No	TBD	Pulse-like
	3	VBW/7	No	TBD	Pulse-like
4	1	VBW	Yes (TBD)	TBD	Noise-like
	2	10 X VBW	No	TBD	CW-like ¹
	3	VBW/10	No	TBD	Pulse-like

NOTE: Spectrum analyzer should be tuned to center the PRF line spectral component.